

**MEFE**  
MITCHELL ENGINEERING  
FOOD EQUIPMENT PTY LTD

# Operating Manual

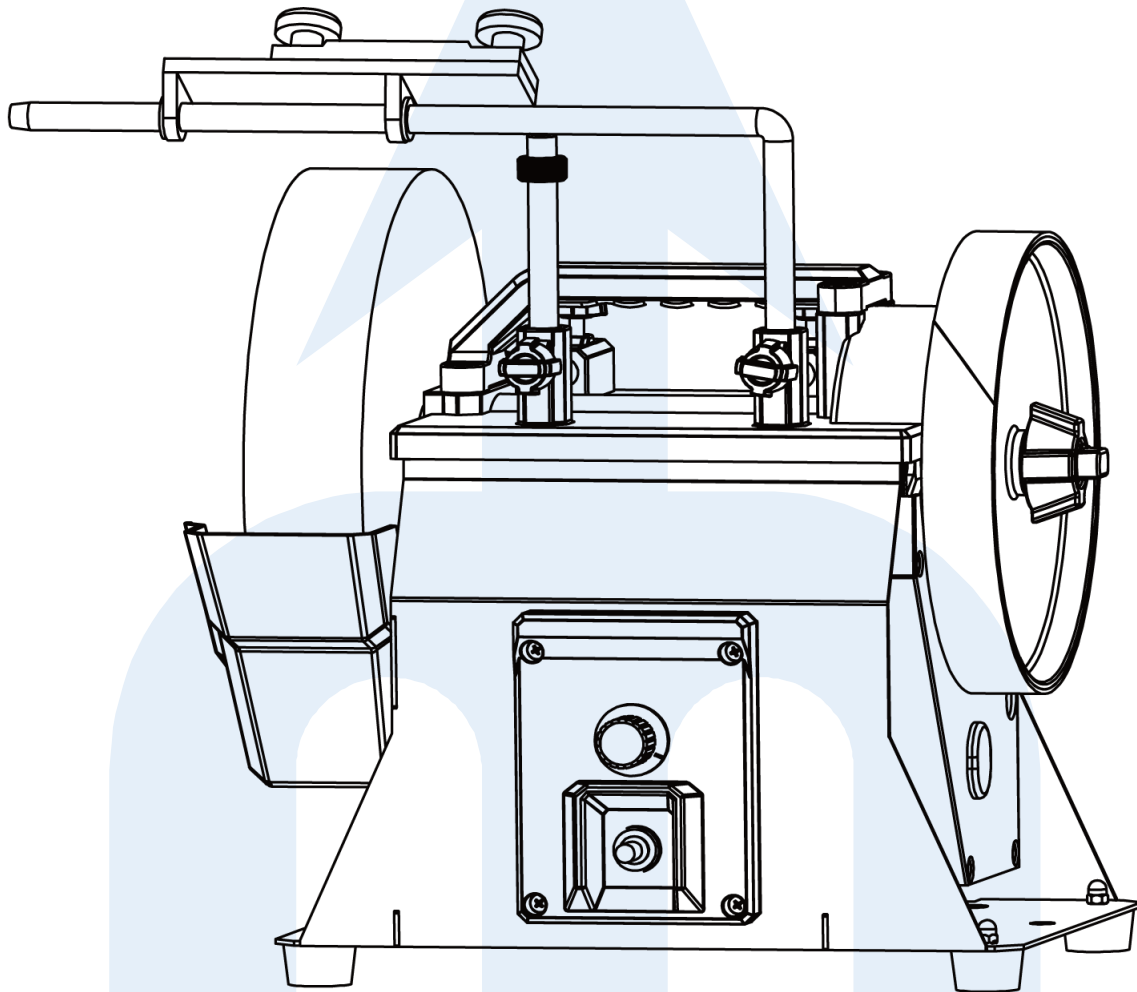

## Variable Speed Knife Sharpener Wet Stone & Leather Honing Wheel

CAT 139 8102

Revision 1

## General Safety Guidelines Before Using this Power Tool

- Always wear eye protection and respirator
- Keep Bystanders out of the work area while operating the tool
- Wheel nuts and eye shields must be properly adjusted and tightened
- Always make sure wheels are properly mounted
- Stand to the side of the sharpener during start up. Switch it on and let the sharpener operate at full speed for approximately one minute so that any undetected flaws or cracks will become apparent
- Keep guards in place and working properly
- Keep hands clear of grinding wheels
- Never reach behind or beneath grinding wheels
- Disconnect power before changing grinding wheels or servicing. The grinding wheels continue to rotate after the tool is switched off. Always allow wheels to stop before adjusting or servicing. **Do not** stop the wheels with your hands or work piece
- To avoid electric shock, **DO NOT** use in damp conditions or expose to rain
- When fitting a new grinding wheel, always check that the stated maximum RPM meets or exceeds the RPM stated on the sharpener, also check the wheel for damage, such as flaws or cracks
- When a new grinding wheel has been fitted, allow a minute of operation before use to check the wheel for flaws
- Only use accessories that are recommended by the manufacturer of your model
- **DO NOT** attempt to cut anything using the grinding wheel
- Grounded tools must be plugged into an outlet that has been properly installed and grounded in accordance with all local codes and standards. Never remove the grounding prong from the plug or modify it in any way
- **Do not** use adapter plugs, if in doubt as to whether the outlet is properly grounded, consult a qualified electrician.
- **Do not** use the tool when tired or under the influence of drugs, alcohol or medication
- **Do not** wear loose clothing, gloves or jewelry; tie up long hair and button all long sleeve shirts
- Ensure the power switch is off prior to plugging in the tool.
- **Do not** over tighten spindle nuts
- Spacing between tool rest and wheels should be set to 1/8" or less; hold work piece firmly against tool rest.
- Service on these tools should only be performed by an authorized, qualified technician



### WARNING

Failure to follow these rules may result in serious personal injury.

## Additional Specific Safety Rules

1. DO NOT operate this machine until it is completely assembled and installed according to the instructions. A machine incorrectly assembled can cause serious injury.
2. OBTAIN ADVICE from your supervisor, instructor, or another qualified person if you are not thoroughly familiar with the operation of this machine. Knowledge is safety.
3. FOLLOW ALL WIRING CODES and recommended electrical connections to prevent shock or electrocution.
4. Failure to adhere to the following can result in fragments flying off the wheel at high speeds.
  - Always use the provided washer and nut to mount the grinding wheel on the sharpener shaft to prevent wheel damage or accidental separation.
  - Use only wheels suitable for the speed of the machine
  - Use only wheels that have a bore exactly equal to the shaft of the machine. Never attempt to machine an undersized wheel to fit the shaft.
  - Do not use a wheel that vibrates. Dress the grinding wheel, replace it, or replace the bearings of the shaft.
5. Do not over tighten wheel nut
6. Inspect wheel for cracks or fragments before starting the machine. Replaced damaged wheels immediately
7. Adjust eye shields close to the grinding wheel, and readjust as the wheel wears down. Flying sparks are dangerous and can cause fires or explosions
8. Always make sure eye shields are properly in place, adjusted and secured
9. ADJUST TOOL RESTS close to grinding wheel (1/8" separation or less). Tighten the tool rest securely to prevent shifting positions and re-adjust as the wheel wears down. The work piece can be drawn into the wheel, causing damage to the work piece and/or serious injury.
10. Make sure the machine is securely placed on a bench or stand before starting motor.
11. Stand to one side before turning the machine on.
12. Never grind on a cold wheel, run for a minute before use, a cold wheel has the tendency to chip.
14. Clean the machine thoroughly when processing different work pieces (wood, steel or aluminium) combining wood & metal dust can create an explosion or fire hazard. Do not grind or polish magnesium. Fire will result.
15. Never start the machine with a piece of work against the grinding wheel, the work piece can be drawn into the wheel, causing damage to the machine and/or serious injury
16. Never grind near flammable gas or liquids. Sparks can create a fire or explosion
17. Avoid awkward operations & hand positions. A sudden slip could cause a hand to move into the grinding wheel
18. Keep arms, hands and fingers away from the wheel. The abrasive surfaces can cause serious injury
19. Always use the tool rest and hold work piece firmly with both hands when grinding.
20. Dress the wheel on the face only, dressing the side of the wheel could cause it to become too thin for safe use
21. Grind a work piece using the face of the grinding wheel only
22. Never apply coolant directly to the grinding wheel, coolant can weaken the bonding strength of the grinding wheel and cause it to fail. Dip the piece in water to cool it.
23. Do not touch the ground portion of a work piece until it has cooled sufficiently. Grinding creates heat.
24. Properly support long or wide work pieces.
25. Never perform layout, assembly or set up work on the table/work area when the machine is running. A sudden slip could cause a hand to move into the wheel.
26. Turn the machine off, disconnect the machine from power source and clean the table/work area before leaving the machine. Lock the switch in the OFF position to prevent unauthorized use.



### WARNING

**Failure to follow these rules may result in serious personal injury. Read, understand and observe all instructions in this manual before using or operating the tool for which it is written and supplied. Ensure that anyone who uses the tool has read and understands the instructions provided.**

## Key Parts Diagram

No.	Description	Part No.	Qty.
1	Horizontal Mounts with Knobs	-	2
2	Universal Support	-	1
3	Leather Stopping Wheel	CAT 139 04	1
4	Vertical Mounts with Knobs	-	2
5	Power Switch	-	1
6	Water Reservoir	CAT 139 05	1
7	Grinding Wheel	CAT 139 02	1
8	Variable Speed Knob	-	1

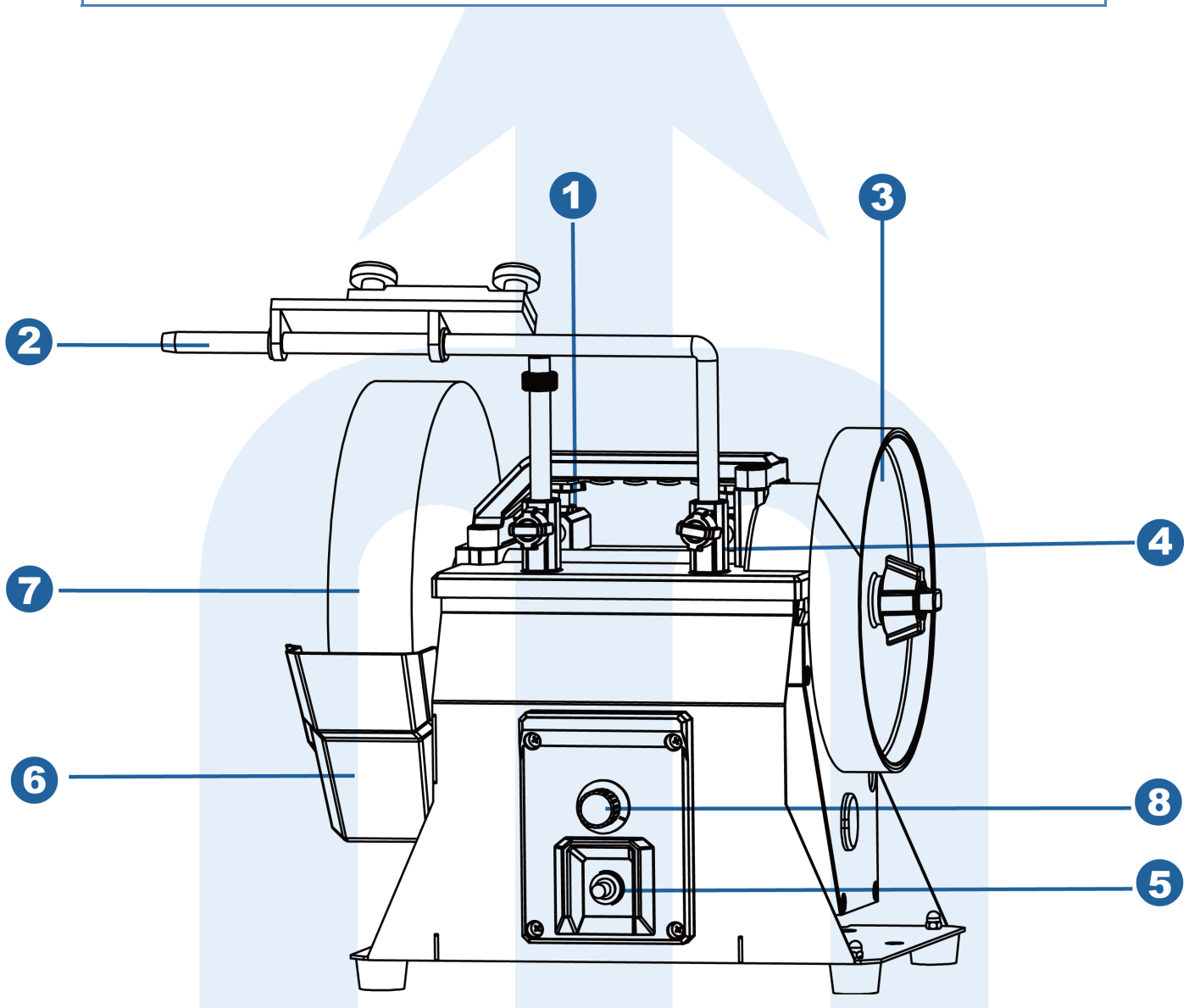

## Package Contents

No.	Description	Part No.	Qty.
1	Sharpener (not shown)		1
2	Universal Support	-	1
3	Grinding Jig		1
4	Wet Grinding Wheel	CAT 139 02	1
5	Water Reservoir	-	1
6	Cord and Plug	-	1
7	Angle Guide	CAT 139 9	1
8	Honing Compound	CAT 139 8	1
9	Lock Knob	-	4

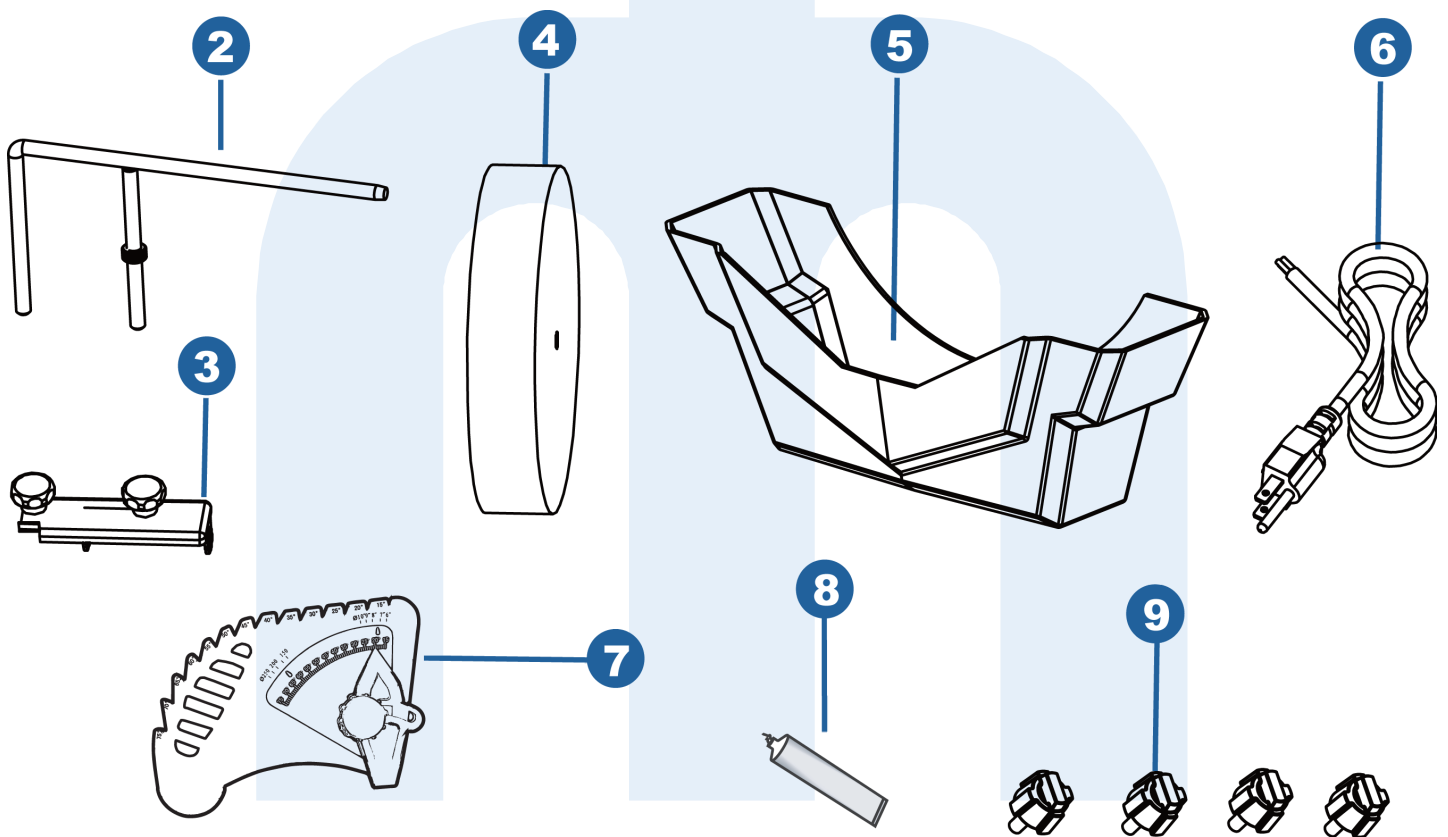

## Operating Instructions

### Mount The Wet Stone

The sharpener is shipped with the Wet Stone (1) off of the machine. Make sure that the machine is not plugged in before assembling the stone onto the sharpener. Remove the nut (3) and outer flange (2) from the main shaft, slide the wet stone onto the shaft, then reinstall the flange (2) and nut (3) to secure the stone in place.

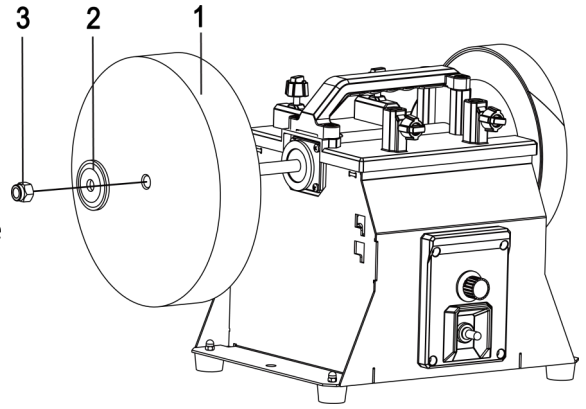

### Mount The Water Tank

Slide the notches on the water reservoir (1) into the two lower mounting slots (2).

**NOTE:** There are two mounting positions on the grinding wheel side of the machine for installing the water reservoir. For new wheels, use the lower mounting slots (2). As the wheel gets used, you will need to adjust the water reservoir to the upper slots (3).

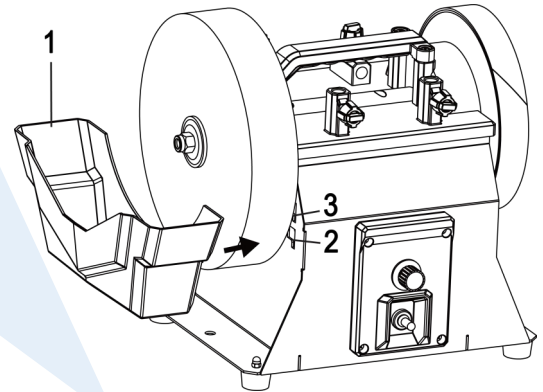

### Installing The Universal Support

The universal support (1) acts as both a work rest and as an attachment arm for various jigs. The universal support can be installed either in the vertical (A) or horizontal (B) position.

#### Position A - Against Wheel Rotation

Working against the rotation of the blade removes larger amounts of material quickly. Use this method for shaping blades or sharpening axes. The grinding wheel rotates towards you.

#### Position B - Along Wheel Rotation

Working along the rotation of the blade is preferable for more precise jobs that require less material removal. For fine sharpening on tools such as knives, scissors, or other carving instruments, grind with the rotation of the wheel. The grinding wheel rotates away from you. Use the two-directional power switch to change the direction of the wheels' rotation. Remove the workpiece from the machine before changing rotation directions.

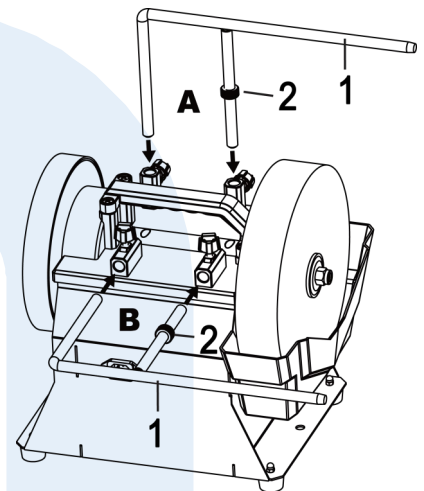

### Mount the Universal Support

1. Select the suitable position for mounting the Universal support. Orient the work support so that the support arm is extended over the wheel you'll be working with.
2. Loosen the mounting locking knobs and slide the work support into the mounting bushings.
3. Adjust the height of the work support to fit your workpiece and operation. Refer to "Angle Guide" for setting up the work support for your blade's bevel using the angle guide.
4. Use the fine adjustment nut (2) on the threaded bar to make fine adjustments to the work support as necessary. Make sure the support arm is completely parallel and level with the face of the wheel, whether it be in the vertical or the horizontal position.
5. Secure the support in place by tightening both locking knobs.

## Grinding Against Wheel Rotation

The sharpener additionally has been outfitted with an electrical power switch that permits the grinding wheel to rotate in the front and reverse directions.

Flip the power switch up, the grinding wheel rotates counter clockwise

Flip the power switch down, the grinding wheel rotates clockwise.

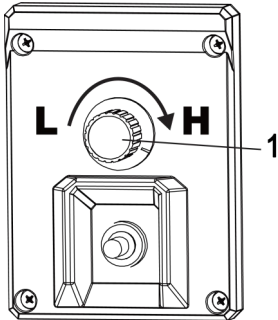
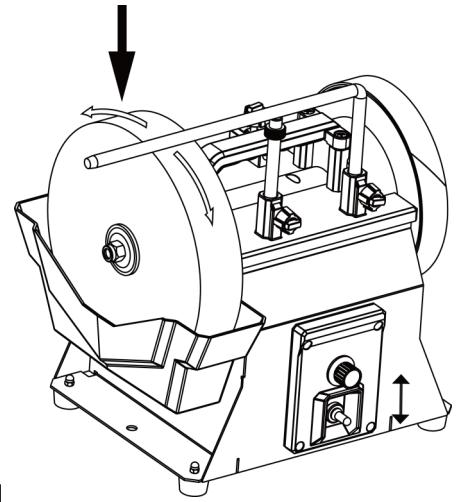

### Variable Speed Knob

1. To increase speed, rotate the carriable speed control knob (1) clockwise
2. To reduce speed, rotate the variable speed control knob (1) counter clockwise.

## Grinding Jig

The grinding jig provided with the wet sharpener is used for securing a variety of tools and can be positioned to grind with and against the wheel rotation.

### To mount the grinding jig

Disconnect Sharpener from power!

Slide the grinding jig onto the universal support as illustrated.

Insert the tool into the jig clamp, then use the angle guide, as described in the manual, to set the grinding angle.

Once the grinding angle is set, tighten both lock knobs to secure the tool in place.

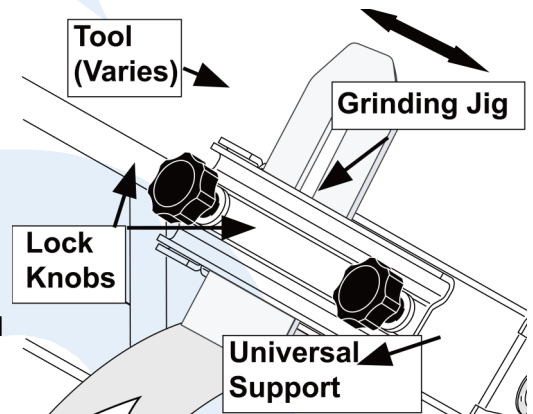

## Water Reservoir

The wet sharpener is designed for wet grinding and should never be used without water.

The mounting tabs on the reservoir serve as hooks to attached to the reservoir mounting slots.

### To fill and position the reservoir:

Remove the reservoir and fill it with water to just below the V shaped notch.

Attach the reservoir to the sharpener.

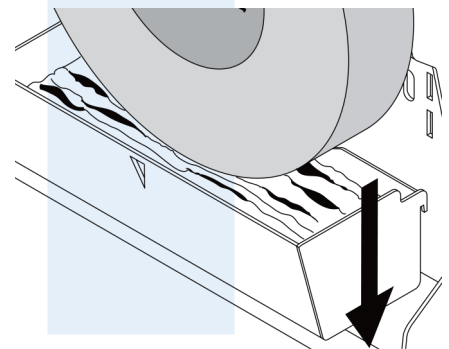

**Note:** If the sharpener is not going to be used immediately, do not put the grinding wheel in water. Remove the reservoir, to reduce the likelihood of damage to the wheel and potential hazards from being stored in water.

**Caution:** Always lock to switch “OFF” when the sharpener is not in use.



## Tips for using the Sharpeners Water Reservoir

- Check the water level before every use and be sure the wheel is wet before you begin grinding. DO NOT use the sharpener without water.
- Leaving the grinding wheel stored in water will cause damage to the wheel, and create potential hazards because the wheel will become unbalanced, Once any grinding process is complete, return the reservoir to the storage position to prevent prolonged water exposure to the wheel.
- Empty and rinse and refill the reservoir regularly. This prevents metal and stone from accumulating in the reservoir.
- Place a magnet in the reservoir to catch and collect metal filings. This will help prevent excessive metal accumulation on the grinding wheel.

## Angle Guide:

The sharpener comes with an angle guide to help identify and maintain the cutting angle on a variety of tools.

1. Mount the blade in the Grinding Jig and place the support arm in the mount.
2. Use the gauge on the outside of the angle guide to measure the bevel angle of the blade.
3. Loosen the locking knob on the angle guide and adjust the protractor so that the arrows are aligned with the correct grindstone diameter marking.
4. Then set the pointer to the required bevel angle on the blade and tighten the locking collar to lock in position.
5. Thread the grinding jig onto the support arm so that the blade rests against the grindstone.
6. Position the curved foot of the angle guide on the grindstone and the flat section of the pointer on the blade to be sharpened.
7. Use the Support Arm Height Adjuster to adjust the height of the support arm until the flat section on the angle guide pointer lies perfectly flat on the blade.
8. The grinding angle will now be correct.

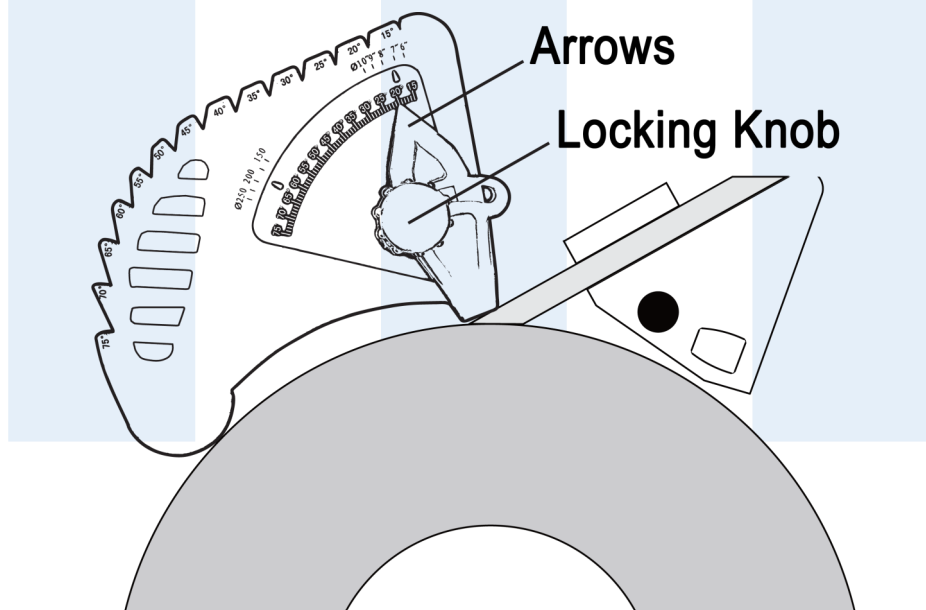



## Wheel Dressing

Depending on the type of grinding you do, the grinding wheel may require periodic dressing. A variety of dressing tools are available (not included) and can be used to restore the abrasive quality of the wheel surface and bring the wheel edge back to the right form. Refer to the instructions that accompany your dressing accessory for complete details on how to properly dress a wheel.

When grinding, metal objects become heated quickly. It is important to keep moving the object back and forth across the face of the grinding wheel and to cool the object frequently using a coolant tray.

## Leather Stropping Wheel

The leather stropping wheel on the sharpener and the included abrasive stropping paste can be used to obtain a razor sharp edge on many tools. Before use, the stropping wheel must be properly prepared.

**Note:** A slight wobble of the stropping wheel when it is rotating is normal and does not affect the performance.

### To Prepare the Stropping Wheel:

1. Evenly apply a light machine oil to the leather wheel. Use enough oil to provide a thorough coating, but not so much and to saturate the leather and result in dripping.
2. Apply a thin coat of abrasive honing paste to the leather wheel using a wooden spreader or similar device. Distribute the paste evenly by hand-turning the wheel while spreading.
3. Connect the machine to power, then turn the machine on and continue to distribute the paste, still using the wooden spreader. Move the spreader lightly in a circular motion across the wheel.
4. Once the paste is evenly distributed, begin sharpening.
5. These preparations will be sufficient for sharpening five to ten tools. If you notice a drop in sharpening performance or have sharpened more than ten tools, repeat the above steps.

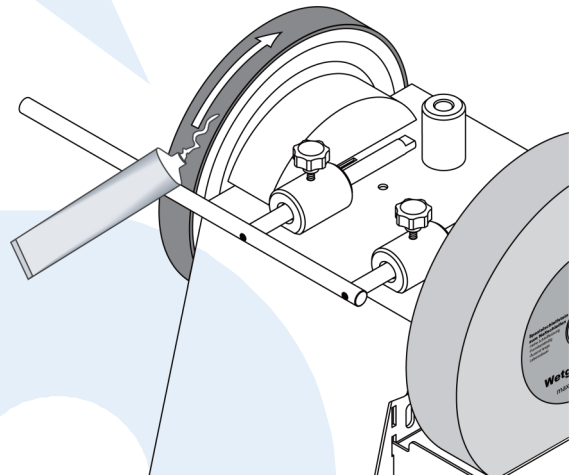

## Maintenance

### Routine Inspection

Before each use, inspect the general condition of the tool. If any of these following conditions exist, do not use until parts are replaced or the sharpener is properly repaired.

- Loose hardware
- Misalignment or binding of moving parts,
- Damaged cord / electrical wiring
- Cracked or broken parts, and
- Any other condition that may affect its safe operation.

## Cleaning and Storage

1. Keep ventilation openings free from dust and debris to prevent the motor from overheating.
2. Use a vacuum or low pressure compressed air to clean debris from tool surfaces, motor housing and work area.
3. Wipe the tool surfaces clean with a soft cloth or brush. Make sure water does not get into the tool.  
**Caution:** Most plastics are susceptible to damage from various types of commercial solvents. Do not use any solvents or cleaning products that could damage the plastic parts. Some of these include but are not limited to: gasoline, carbon tetrachloride, chlorinated cleaning solvents, and household detergents that contain ammonia.
4. Always empty the water reservoir and wait for the grinding wheel to dry completely before storage. Do not store the machine with a wet or damp grinding wheel.
5. Store the tool in a clean, dry place away from the reach of children. Store in temperatures between 5° - 30°C. Cover the tool in order to protect it from dust and moisture. It is preferable to store it in its original packaging.

## Lubrication

Check the gearbox monthly and add a small amount of white-lithium grease if necessary.

## Replacing the Stropping Wheel

Inspect the leather stropping wheel for any damage or wear before each use. If the leather stropping wheel becomes damaged or worn, replace it as follows.

1. Unscrew the locking knob (3).
2. Remove the outer flange (2) and stropping wheel (1) from the spindle
3. Install a new wheel, reinstall the outer flange and locking knob, tighten the locking knob by hand.

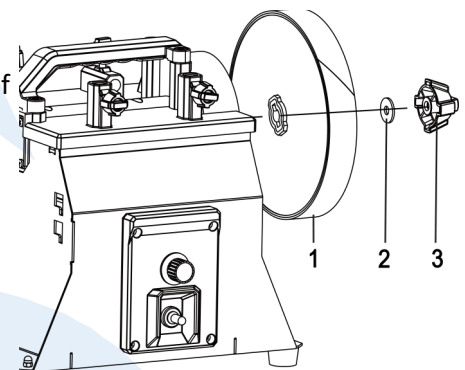

## Trouble Shooting

Symptom	Probable Cause	Corrective Action
Motor will not start	Low voltage	Check Power source for proper voltage
	Open circuit in motor or loose connections	Send for service
	Blown fuse or breaker	Replace fuse or reset breaker
Motor overheats	Motor Overload	Reduce load on motor
	Extension cord too long and of insufficient gauge	Utilize an extension cord of appropriate gauge and length or plug tool directly into outlet
Motor stalls (resulting in blown fuses or tripped circuit)	Short circuit in motor or loose connections	Send for service
	Low voltage	Correct low voltage conditions
	Belt Loosen	Tighten the drive belt
	Motor Overload	Reduce the load on the motor
Stropping wheel looses performance	Insufficient wheel preparations	Prepare wheel
	Wheel is damaged	Replace the wheel
Wavy Condition on surface of work- piece	Machine is vibrating	Make sure machine is positioned on a level surface
	Workpiece is not help in place firmly	Use a holding device to firmly retain the workpiece
	Wheel face is uneven	Dress the grinding Wheel

## Exploded View

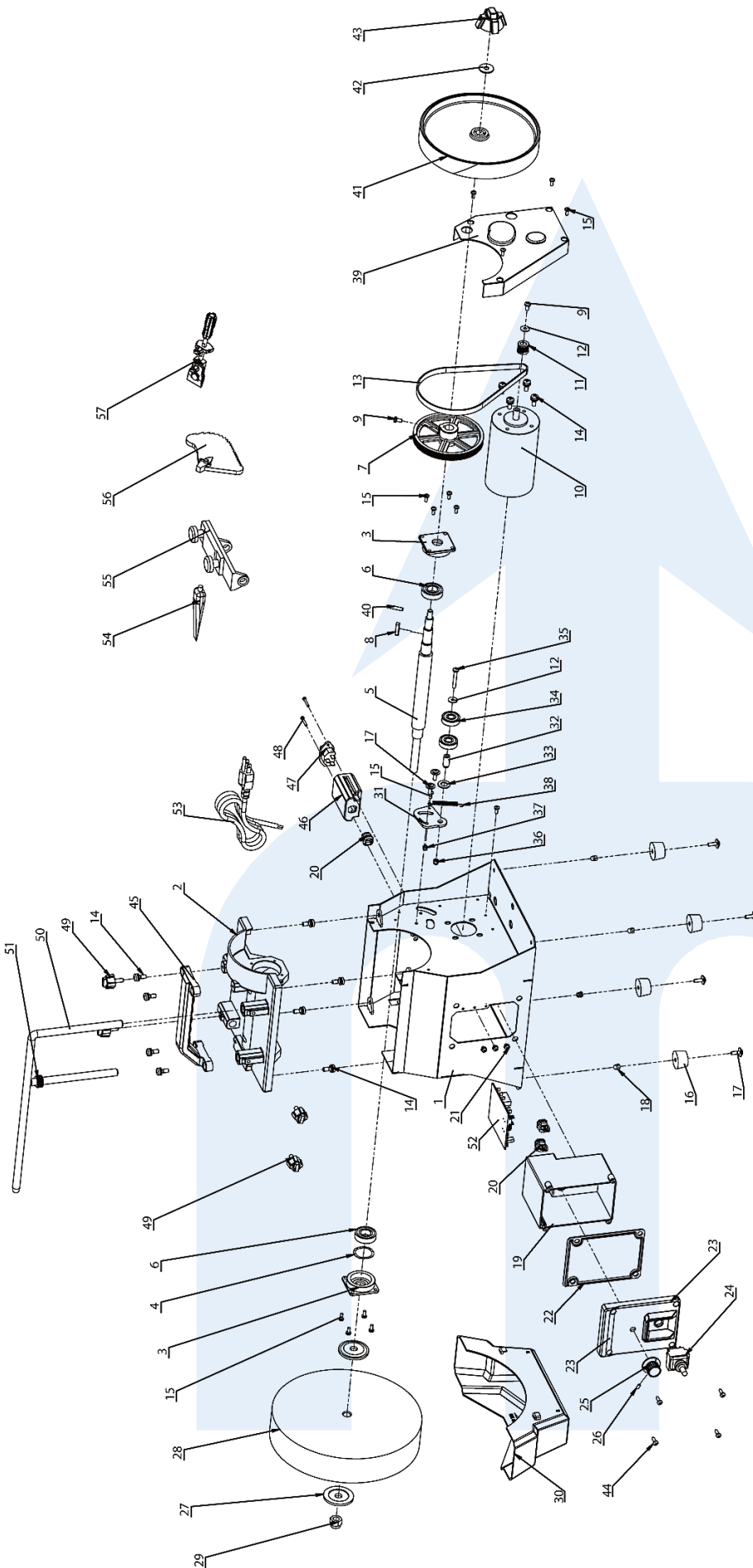

No.	Description	Qty
1	Base Assembly	1
2	Bearing Housing	1
3	Bearing Block	2
4	Wave Washer D35	1
5	Main Shaft	1
6	Ball Bearing 6003-2RZ	2
7	V-Belt Pulley	1
8	Flat Key 5x5x25	1
9	Phillips Screw M5x10	2
10	Motor	1
11	Motor Pulley	1
12	Big Flat Washer D35	2
13	V-Belt	1
14	Phillips Screw M6x16	12
15	Phillips Screw M4x10	14
16	Rubber Foot	4
17	Phillips Screw M5x20	6
18	Nut M5	4
19	Wire Connection Box	1
20	Power Cord Clip 6P4	3
21	Phillips Screw M4x7	2
22	Rubber Mat	1
23	Switch Plate	1
24	Power Switch	1
25	Speed Control Knob	1
26	Bolt M4x8	1
27	Flange	2
28	Grinding Wheel	1
29	Nut M12	1
30	Water Reservoir	1
31	Bearing Plate	1
32	Bearing Shaft	1
33	Washer D10	1
34	Ball Bearing 6200-2RS	2
35	Phillips Screw M5*35	1
36	Nut M5	1
37	Nut M4	1
38	Tension Spring	1
39	Belt Guard	1
40	Round Pin 6x22	1
41	Polishing Wheel	1
42	Big Flat Washer A8	1
43	Lock Knob M8	1
44	Phillips Screw ST4.2x16	4
45	Handle Assembly	1
46	Socket Box	1
47	Socket	1
48	Phillips Screw M3x20	2
49	Lock Knob M6x16	4
50	Universal Support	1
51	Adjustment Knob	1
52	Circuit Board	1
53	Cord & Plug	1
54	Honing Compound	1
55	Grinding Jig	1
56	Angle Guide	1
57	Short Knife Jig	1

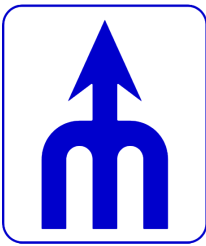

**MEFE**  
MITCHELL ENGINEERING  
FOOD EQUIPMENT PTY LTD

# Sharpening Guide



## Sharpening guide for Jigs

Compatible wheel diameter  $\varnothing$ 150mm -  $\varnothing$ 250mm

Revision 1

## CAT 139 9

Included with CAT 139 8100, CAT 139 8101 & CAT 139 8102

### Using the Grinding Angle Set-Up Jig

Use the Grinding Angle Set-Up Jig to set the blade at exactly the correct angle for sharpening.

1. Mount the blade in the Straight Edge Jig and place the support arm in the mount  
**Note:** *The Grinding Angle Set-up Jig can be used in conjunction with other jigs in the MEFE range.*
2. Use the gauge on the outside of the Grinding Angle Set-Up Jig to measure the bevel angle of the blade.
3. Loosen the locking knob on the Grinding Angle Set-Up Jig and adjust the protractor so that the black arrows are aligned with the correct grindstone diameter marking
4. Then set the pointer to the required bevel angle on the blade (as measured in Step 2, above) and tighten the locking collar to lock in position
5. Thread the Straight Edge Jig onto the support arm so that the blade rests against the grindstone
6. Position the curved foot of the Grinding Angle Set-Up Jig on the grindstone and the flat section of the pointer on the blade to be sharpened
7. Adjust the height of the support arm until the flat section on Grinding Angle Set-Up Jig pointer lies perfectly flat on the blade

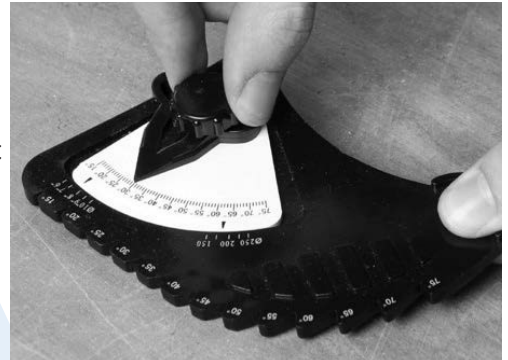

### Using the Straight Edge Jig

Included with CAT 139 8100, CAT 139 8101 & CAT 139 8102

For use with the Support Arm and Grinding Angle Set-Up Jig to set the blade at exactly the correct angle for sharpening

1. Loosen the knobs on the Straight Edge Jig
2. Place the blade in the jig so that one edge of the blade is positioned against the end stops
3. Tighten the knobs to fasten the blade in position

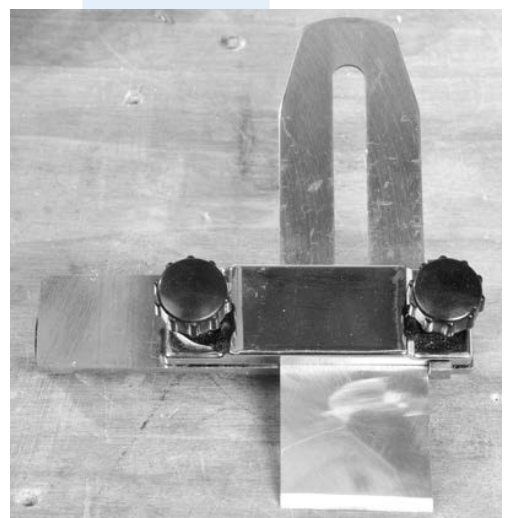



## Using the Support Arm (Included with CAT 139 8100, CAT 139 8101 & CAT 139 8102)

The Support Arm can be attached for grinding with or against the direction of rotation of the grindstone

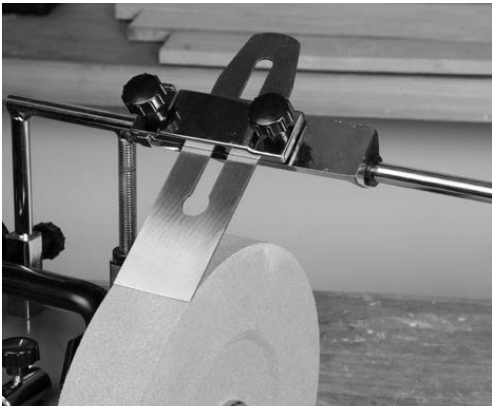

**For grinding against the direction of rotation:**  
Place the Support Arm in the Vertical Mounts

**For grinding and honing with the direction of rotation:**  
Place the Support Arm in the Horizontal Mounts

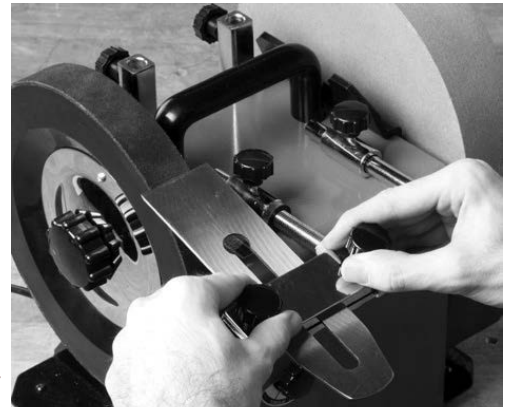

**WARNING:** Honing must ONLY be carried out WITH the direction of rotation.

- Working against the direction of rotation removes larger amounts of material more quickly than working with the direction of rotation
- Working with the direction of rotation can be used for very precise sharpening of a blade for finer tools and is used for honing
- Take your time and practise the set up with various types and sizes of blades so that you can achieve the correct sharpening angle and ensure the blade to be sharpened is square across the surface of the grindstone
- In general, for sharpening, position the support arm in the vertical mounts and sharpen against the direction of rotation
- NEVER place the support arm in the vertical mounts when using the leather honing wheel. Attempting to hone the blade against the direction of rotation will cause severe damage to the honing wheel

## Long and Short Knife Jig

Included with CAT 139 8100 & CAT 139 010

1. Blade Clamp
2. Adjustable Jig Stop
3. Clamp Thickness Screw
4. Jig Tightening Knob
5. Jig Stop Adjustment Knob

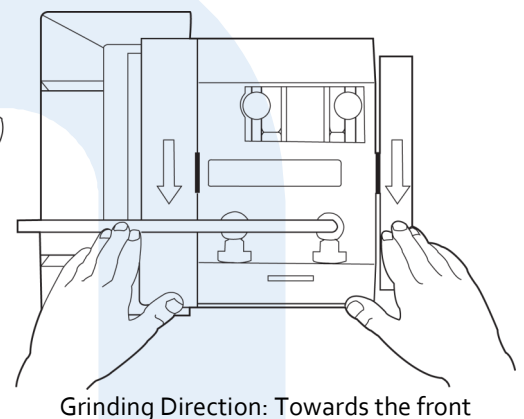
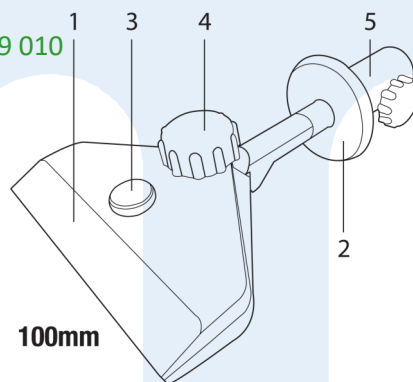

### Using the Long or Short Knife Jig:

- The Blade Clamp (1) is designed for holding knives of any thickness, which is fully adjustable with the Clamp Thickness Screw (3)
- The Adjustable Jig Stop (2) can be moved into the desired position based on the knife's size by easily loosening Jig Stop Adjustment Knob (5), moving the Jig Stop then retightening the Jig Stop Adjustment Knob
- Lock the Long Knife Jig by tightening the Jig Tightening Knob (4)
- Use the Support Arm to rest the jig on and use the Adjustable Jig Stop to steadily control sharpening of the knife

**Note:** The long knife jig is especially designed for use with long and thin knives, such as filleting knives. Because the Long Knife Jig is wide, it provides ample support required for long, thin blades.

## Scissors Jig

Restores sharp edges to blunt scissors and garden shears. Twin clamps for securing blades.

Included with CAT 139 8100 & CAT 139 010

1. Jig Support Plate
2. Scissor Clamp Holder
3. Scissor Clamp
4. Clamp Thickness Screw
5. Jig Tightening Knob

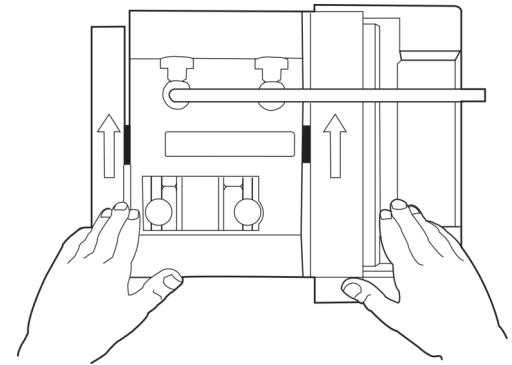
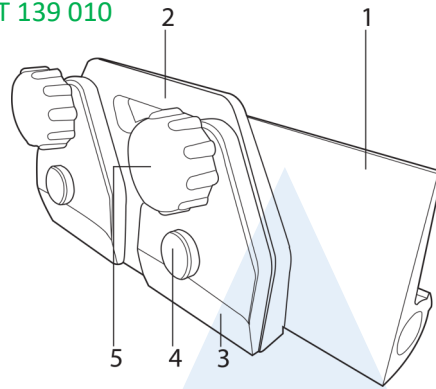

### Using the Scissors Jig:

- The Scissor Clamp Holder (2) is fitted with 2 Scissor Clamps (3). Normally, only the Scissor Clamp on the right is required; however, for large scissors or shears the other clamp can also be used
- Adjust the Scissor Clamp/s to fit the scissor blade thickness. Loosen the Jig Tightening Knob (5) then the Clamp Thickness Screw (4). Insert the scissor blade and re-tighten
- The Jig Support Plate has a surface designed to allow the jig to move easily while sharpening

**IMPORTANT:** DO NOT use the Leather Honing Wheel to remove the burr from the scissor blade after using the Grindstone. To remove the burr, draw the scissor blade through the grain at the end of a piece of wood.

**Note:** Portable electric-planer blades (not tungsten carbide blades) are ground in the same way as scissor blades; however, honing using the Leather Honing Wheel is required.

### Setting the bevel edge angle

- The scissors' bevel edge angle is set by adjusting the Jig Support Plate. Either repeat the existing angle or create a new bevel edge angle by using the Grinding Angle Set-Up Jig

### The same bevel edge angle:

1. Slide the Jig Support Plate (1) onto the Support Arm and tighten
2. Use a black marker pen to colour the bevel edge of scissor blade; rest the jig on the Jig Support Plate with the scissors' bevel edge touching the grinding wheel; and, using your hand, turn the grinding wheel a quarter turn
3. Check the bevel edge to see what part of the black pen mark has been scratched off, then adjust the Jig Support Plate to correct the angle
4. Re-test the quarter-turn scratch and re-adjust the Jig Support Plate if required

### A new bevel edge angle:

1. Slide the Jig Support Plate onto the Support Arm and tighten
2. Use the Grinding Angle Set-Up Jig to set-up the Scissor Jig at the new angle (see 'Using the Grinding Angle Set-Up Jig')





## Axe Jig

Included with CAT 139 8100 & CAT 139 010

### Using the Axe Jig:

The jig is designed so that the rotation of the stone presses the axe firmly into the jig. You only need to hold and guide the axe with your hands. This jig only works with the stone running towards the edge. If necessary, the honing wheel can be removed to allow clearance for the axe handle.

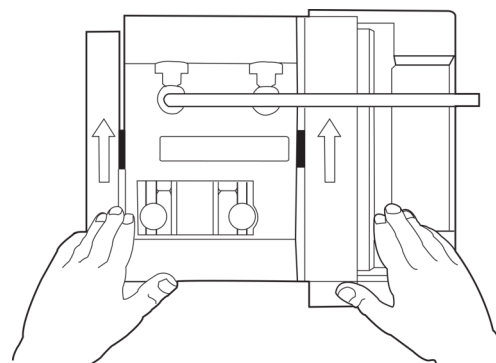

Grinding Direction: Towards the edge

1. Place the axe into the jig. Set the edge angle by adjusting the Universal Support. Either at the original angle or at a new angle using the Angle Guide Jig.
2. Press with your palm on the axe, close to the stone. The axe will automatically be pressed up against the stop in the jig and the grinding is most efficient.
3. Follow the shape of the edge (straight or curved) during grinding by raising or lowering the handle. Let the jig slide sideways on the Universal Support so that the stone wears evenly.

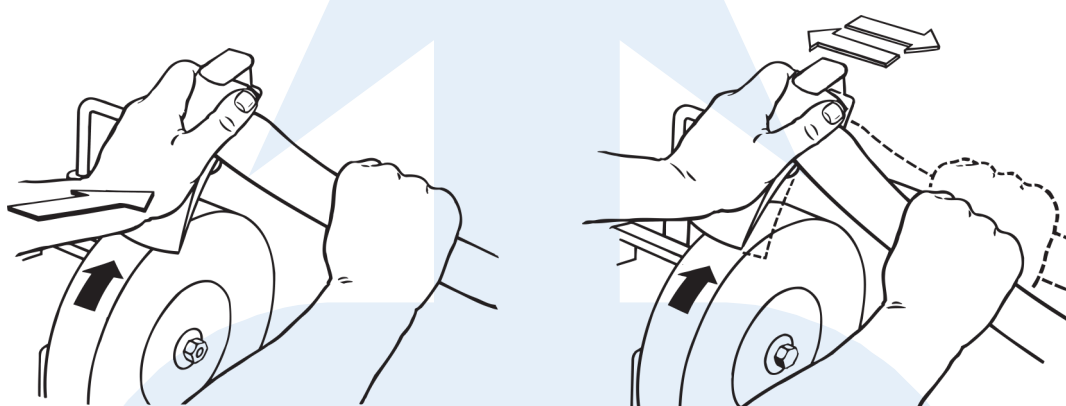

### Edge angle

- The edge angle of a carpenter's axe or hatchet should be 25–30°, depending on the hardness of the wood. Grind the edge with a smaller bevel angle on the side towards the wood than on the other side. This longer bevel gives you a good support towards the wood. Also, as the axe works closer to the surface of the wood, the cutting will be more effective and easier to control.
- A felling axe and a hunting axe must have a larger edge angle, 30–40°, so that the edge is more durable. Round off the heels of the bevels and the axe cuts more easily. This is done by lowering the Universal Support and grinding in two steps.

### Honing

Honing and polishing the bevels on the leather honing wheel makes the edge cut more easily and the sharpness will stay longer. Always hone away from the edge.



## Machine and Pack Information

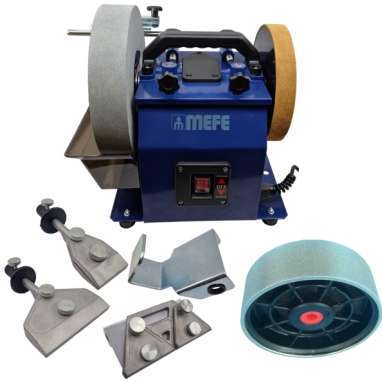

### CAT 139 8100 - Knife Sharpener Bundle

Includes:

- 1 x CAT 139 8101 - Knife Sharpening Machine
- 1 x CAT 139 010 - Knife and Blade Jig Set
- 1 x CAT 139 02 10 - 200mm 1000 Grit Diamond Sharpening Wheel



### CAT 139 8101 - Knife Sharpening Machine

Includes:

- 1 x Knife Sharpening Machine
- 1 x 250mm 220 Grit Grinding Wheel
- 1 x 200mm Leather Honing Wheel
- 1 x CAT 139 9 Angle Guide Jig
- 1 x Honing Paste
- 1 x Straight Edge Jig
- 1 x Universal Support Bar

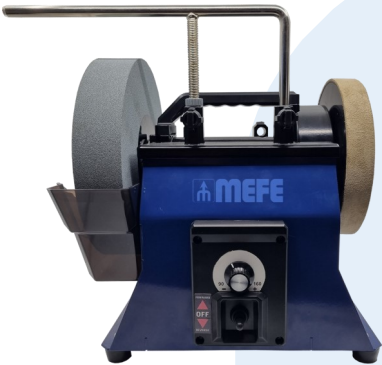

### CAT 139 8102 - Variable Speed Knife Sharpening Machine

Includes:

- 1 x Variable Speed Knife Sharpening Machine
- 1 x 250mm 220 Grit Grinding Wheel
- 1 x 200mm Leather Honing Wheel
- 1 x CAT 139 9 Angle Guide Jig
- 1 x Honing Paste
- 1 x Straight Edge Jig
- 1 x Universal Support Bar

### CAT 139 010 - Knife and Blade Jig Set

Includes:

- 1 x Short Knife Jig
- 1 x Long Knife Jig
- 1 x Scissors Jig
- 1 x Axe Jig



### CAT 139 9 - Angle Guide

Includes:

- 1 x Variable Angle Guide Jig

