

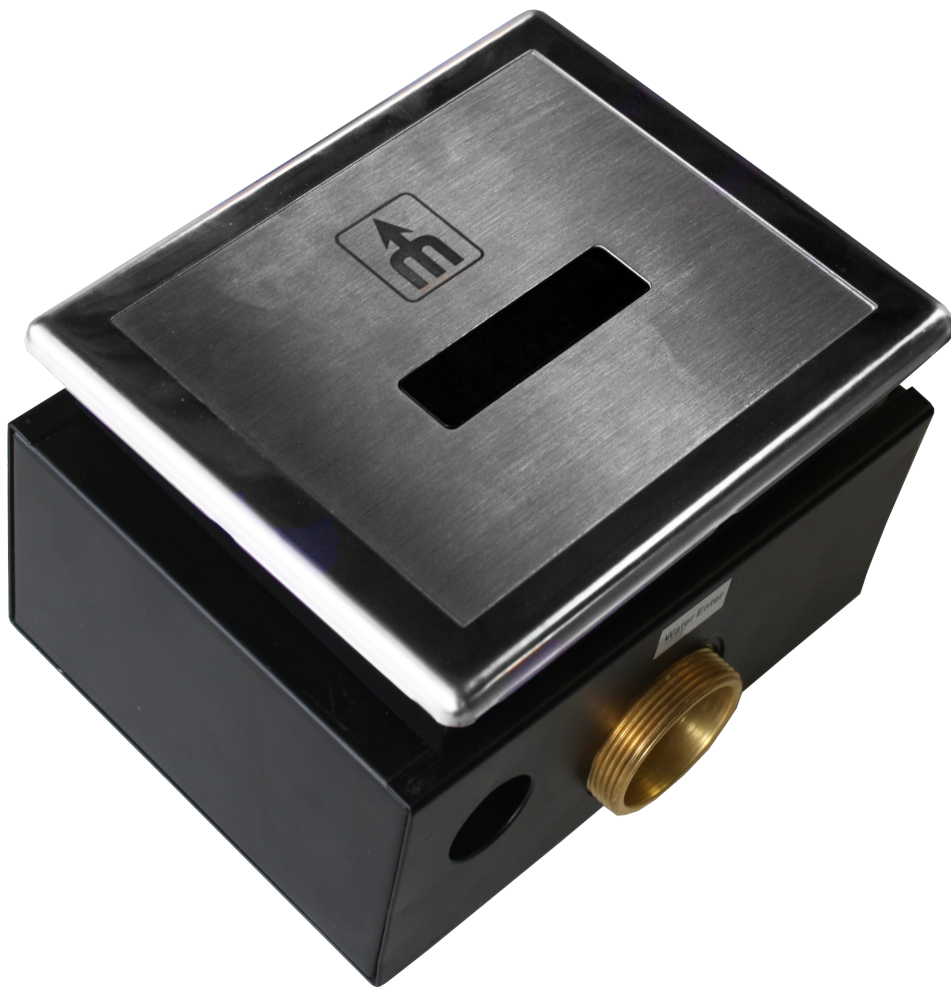

MEFE
MITCHELL ENGINEERING
FOOD EQUIPMENT PTY LTD



CAT 67201

Automatic Toilet Sensor Installation Manual

Revision 2



1800 669 006

info@mefe.com.au

www.mefe.com.au

Unauthorized reproduction or use of information herein is strictly forbidden



Installation Precautions

- Before installation this product all pipes should be flushed with clean water to remove any impurities or silt in the pipeline.
- Working pressure is 0,5 kPa – 6 kPa. The inlet pipe should be 1 inch and as long as possible to allow for maximum water volume to run through the valve.
- Avoid reflections in front of the sensor such as mirrors, marble or stainless steel etc.
- Do not install in direct sunlight.

Specifications

Model #	CAT 67201	CAT 67206
Power Supply	AC 220v 50-60Hz	DC6V, 4 pcs1.5V, AA Alkaline batteries
Sensor Distance	70 cm (Standard white sensor board)	
Dimension	12 cm x 14 cm x 6 mm	
Flushing Style	2 Stages water-flushing	
Inlet Water Pipe	G 1"	
Water Pressure	0,5kPa ~ 6kPa	

Name of Parts and Structure Diagram

1. Water Inlet
2. 1 inch screw nut
3. Water volume adjuster
4. 220v power wiring
5. Battery box
6. Valve Cover
7. Solenoid Valve
8. Output Power Plug
9. Solenoid valve plug
10. Slurry Mould
11. Water Outlet

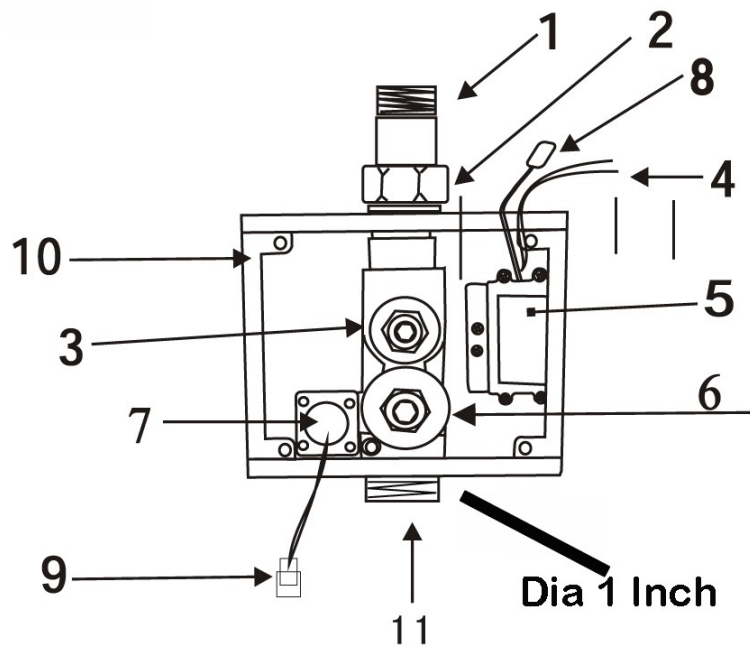

Installation

Division Size of Unit:

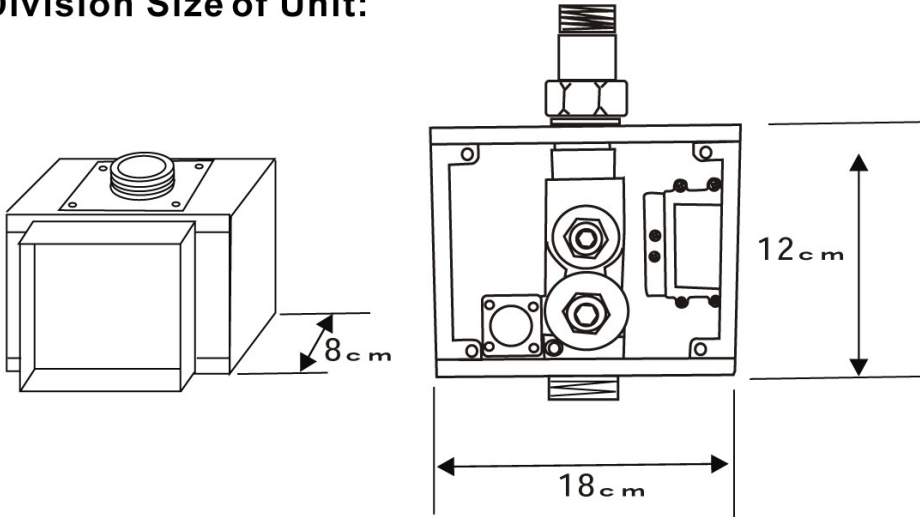

1. When installing this product, please make sure to cut appropriate point according to product size.

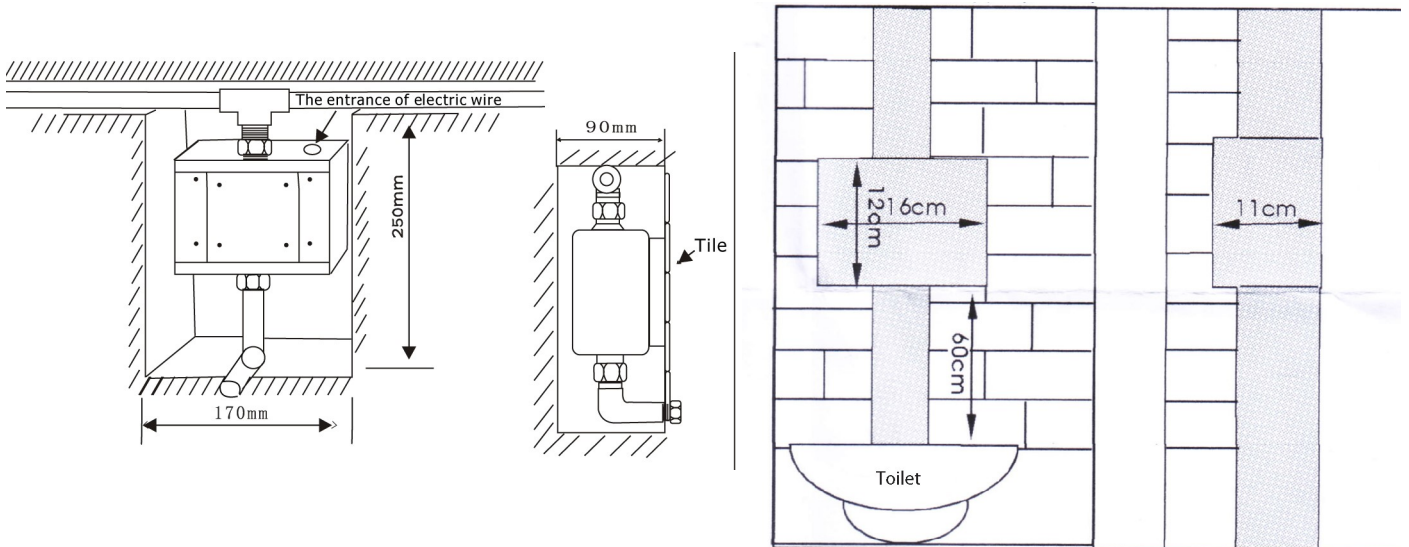
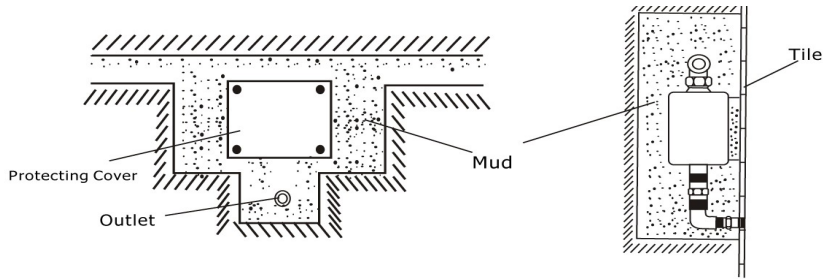

2. Please clean impurities and silt from pipeline. Screw down the water inlet nut and connect to pipeline.

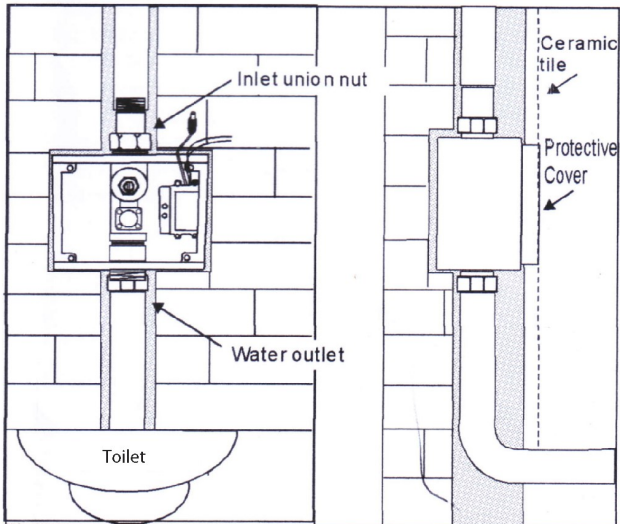

3. Please check interface for leaks during water pressure test. Grout the gap between control box and the wall and stick tiles down. Once grout is dry, remove and dispose of protective cover.

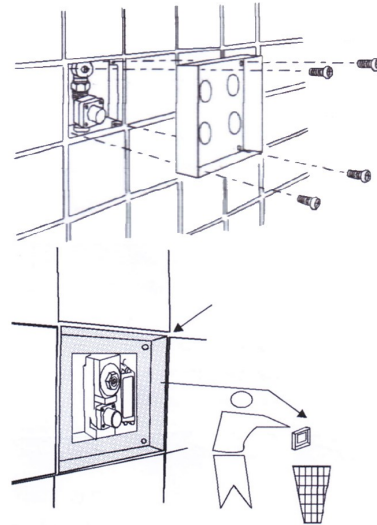

4. Open the battery holder and insert 4 x AA alkaline batteries. Connect sensor panel, power cables and solenoid valve. Put the power adapter and battery holder back into the mortar. When the power is turned on, the LED light will flash once.

Note: a) Do not mistake the polarity of the batteries. Do not mix old and new batteries.

b) Tighten the screws on the battery box to eliminate moisture around the batteries

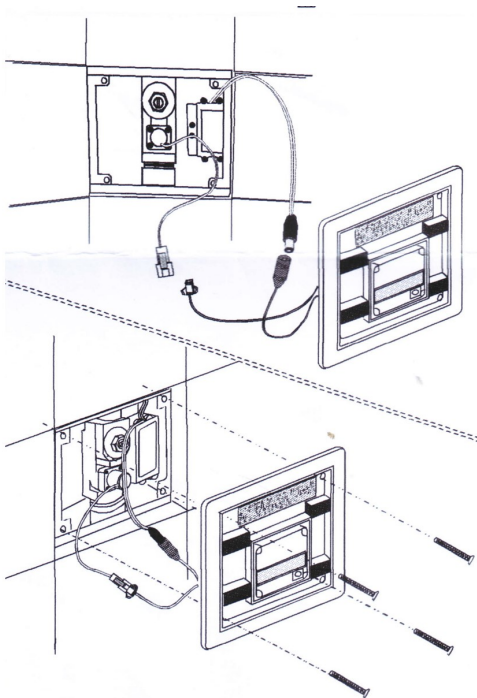

5. Screw the fixed panel with 4 long screws and cover the panel.

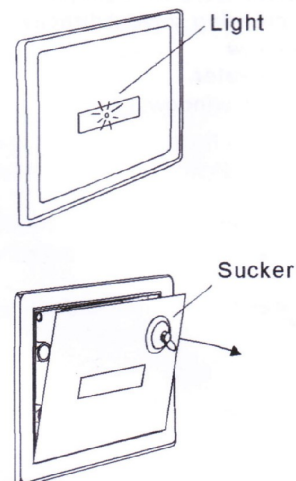
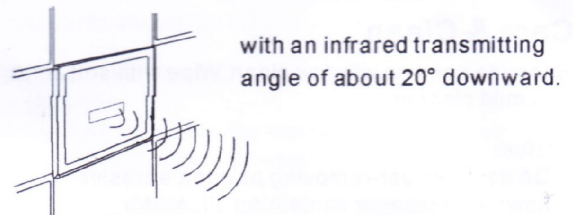

Note: The sensing distance is set 70cm away from the sensing window, along the direction of the transmitting angle. Transmitting angle of 20° downwards.

To adjust water flow, use a small screw driver and turn valve clockwise to shut off or anti – clockwise to open.

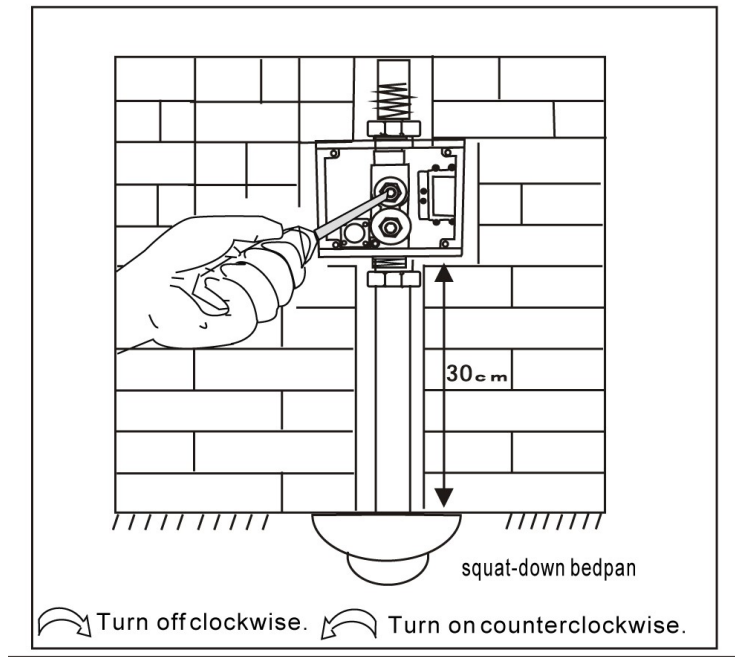

Forced Water Induction – CAT 67206

If you need to force flush, you can flush the toilet mandatory with the **CAT 67206** valve. Every time the user pushes the button, the valve will flush for 6 seconds and shut off automatically.

When the toilet hasn't been flushed for a long time, the sensor will drive the solenoid to flush every 24 hours to keep it clean and deodorised.

When user passes into the sensing range for 2 seconds, the valve will flush for 2 seconds. Once the user has left the sensor, the valve will flush for 6 seconds. (LED light will flash once every 3 seconds.

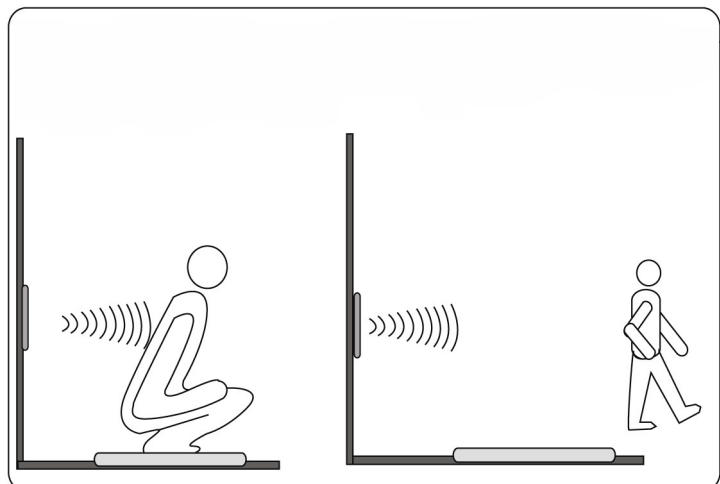
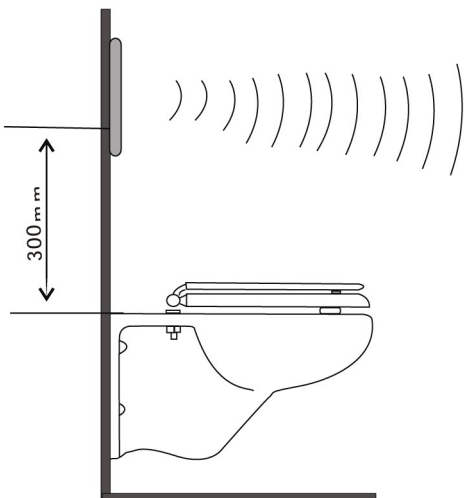

Maintenance

Clean the filter screen.

If the flushing volume reduces sharply after installation or the valve has been used for a long time, with no cause from the water pressure, then the filter may need cleaning. Using a small screw driver, turn off the fixed cap. Take out the filter and clean with a brush and re-install it.

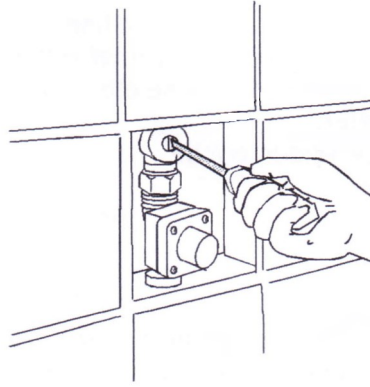

Note:

- a. Turn off the water supply or tighten the adjusting bolt before cleaning.
- b. Carefully remove the filter when cleaning to avoid foreign materials from entering inside the valve body.

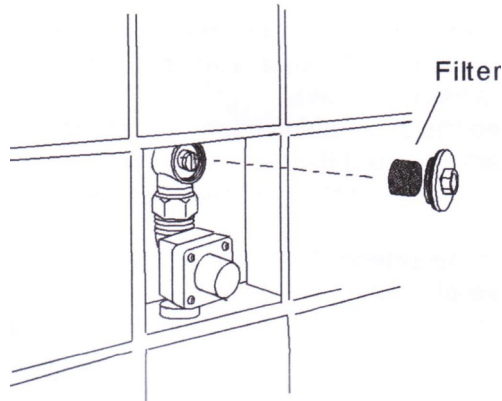

Cleaning

Keep the sensing window clean. Wipe with a soft cloth and use only soapy water.

Note:

- a. Do not use dust removing powder, abrasive powder, bleach, oil, acid or alkaline based products.
- b. Do not spray air refresher, disinfectant or other deodorising or cleaning solvent directly onto sensor window.
- c. Keep power wires away from water.

Troubleshooting

PROBLEM	REASON	SOLUTION
NO WATER FLOWING	<ul style="list-style-type: none"> • The power supply or valve hasn't been switched on. • Batteries are flat. • Not plugged into socket correctly • There are obstacles before the sensor window. 	<ul style="list-style-type: none"> • Turn on the water valve or switch the power on. • Replace the batteries • Plug socket in well • Check sensor window is clear of obstacles up to 1 meter
CAN'T SHUT OFF WATER	<ul style="list-style-type: none"> • Water pressure is too low. • Solenoid is blocked • Batteries have gone flat. 	<ul style="list-style-type: none"> • Increase the water pressure • Open the solenoid valve and clean out any impurities and silt.
LITTLE AMOUNT OF WATER FLOWING FROM VALVE	<ul style="list-style-type: none"> • Water pressure is too low. • Water regulation valve is not opened enough 	<ul style="list-style-type: none"> • Increase water pressure. • Open the water regulation valve to its full open position.

EXPLODED VIEW

