



**CAT 67801-3SB**  
**Automatic Sensor Tap Installation Manual**  
**MATTE BLACK**

## Product Description

- Infrared sensor tap, water will automatically flow from faucet when hands are detected within the sensing range. The faucet will stop flowing once the users hands leave the sensing range.
- With a microcomputer sensor control module, low consumption micro processed chip allows for stability and strong anti-interference function.
- PCB electronic control module is double sealed and fixed inside the faucet. Coated by high performance water-proof membrane and then sealed with epoxy resin. Stable in moist environments.
- Faucet body made from solid brass. Surface of tap is electroplated, to prevent brass surface from corroding and a shiny finish.
- The sensor faucet is highly produced and frequently tested, to ensure the quality of the product reaches national standard

## Technical Data

- Faucet spout material: solid brass with chrome finish
- Power Supply: AC 220v or DC 6v ( 4pcs x AA Alkaline batteries)
- Battery Life: 150 000 cycles
- Sensing Range: 10cm to 25cm ( adjustable )
- Working Temperature: 1 ~ 60°C
- Water Pressure: 0.07Mpa ~ 0.7Mpa
- Supply inlet size: BSP ½ (DN15), male thread
- Installation Diameter: single hole 32mm
- Response Time: less than 0.7 seconds
- Water Flow Rate: If water pressure is less than 0.3 Mpa – less than 3 l/s
- Humidity: under 95%



## Operation:

Infrared rays are continuously emitted from the sensor faucet.



When the user's hand moves in front of the sensing window, the solenoid valve is activated and water will flow out.



When the user moves their hands away from the sensor, the solenoid will close and the water flow will stop. The faucet will reset for the next user.



## Attention:

*When the user uses the faucet for more than 60 seconds, or faucet is activated for a long period, the solenoid valve will close automatically, until the user steps away from the sensor. Sensor will reset for normal use.*

**Diagram and Parts Name**

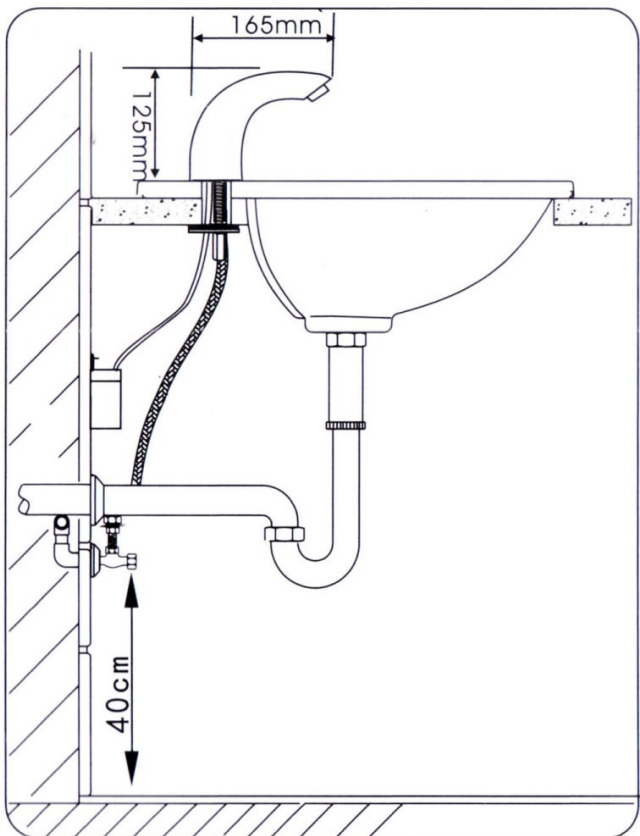
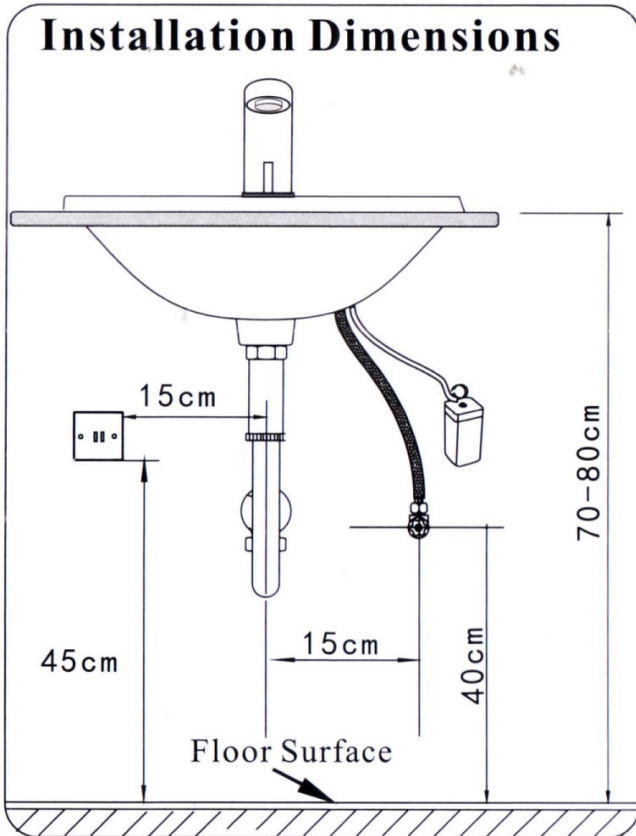
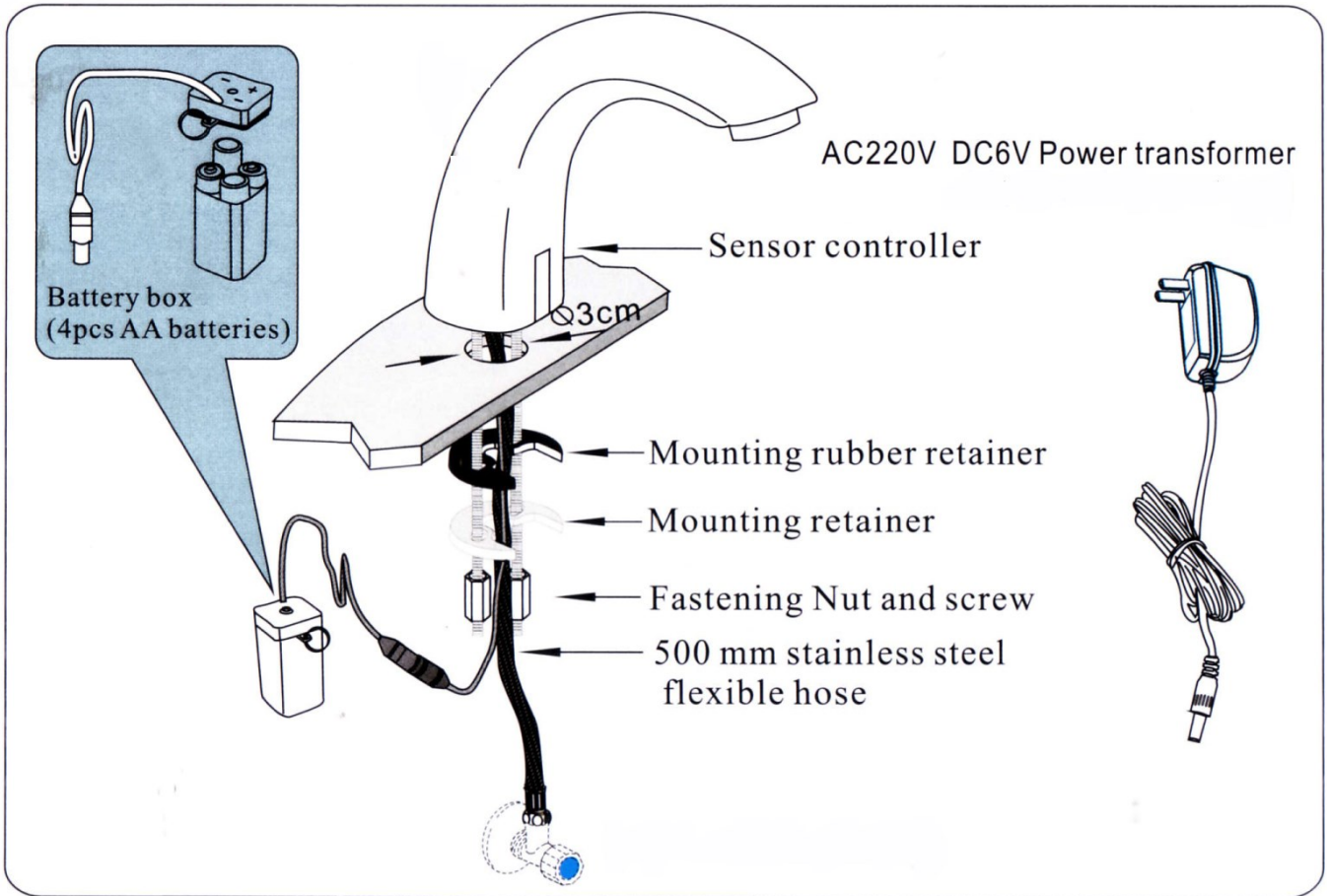

## Prior to Installation

Please choose the right basin prior to installation

**Warning:** Sensor of the faucet must be higher than the basin or lavatory. Minimum of 15mm.

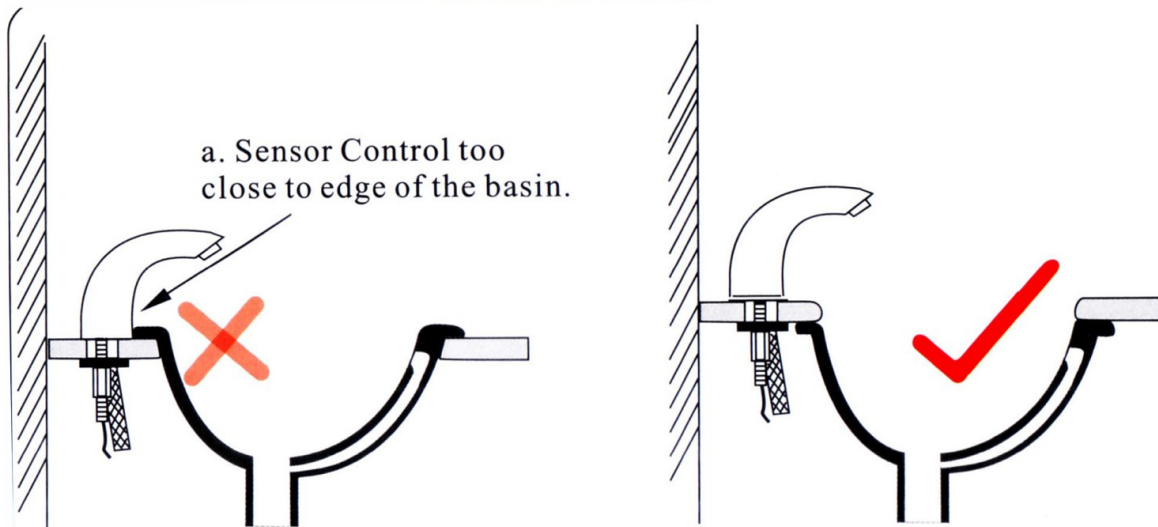

## Tools required

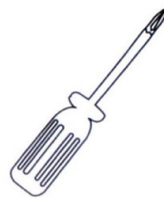

a. 12 mm socket screw driver.    b. Philips head screw driver.    c. Shifter Spanner

## Prepare and Install below item prior to install the Faucet

- Drainage and waterproof Power Point (for AC type) are already installed.
- Ensure all pipes are cleared before the connection!

# If need adjust water temperature, a cold and hot water mixer and 2 extra with 1/2 BSP nut on both end and 200 mm long flexible hose are required.

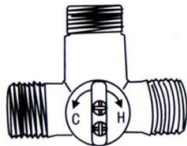

a. Cold and hot water mixer.



b. 1/2 BSP nut on both end and 200 mm long flexible hose

## Additional Spare Parts

**CAT 67M - Pre-set mixing - HOT AND COLD MIXING**

**1/2 " connections**

**Non return on both inputs**

**Work exceptionally well with auto valve**





## Prior to installing faucet, prepare the items listed below.

- Please choose the right basin before installation.
- Water supply pipe and water-proof socket (for electricity type).
- Hot/Cold water inlet flexible hose with 1/2 inch BSP nut on both ends. (Water temperature should be less than 40 degrees )
- Ensure all pipes are cleared of any dirt before installation.

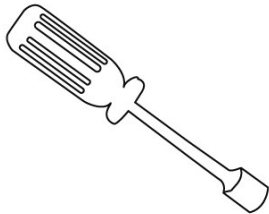

a. 12 mm socket screw driver.

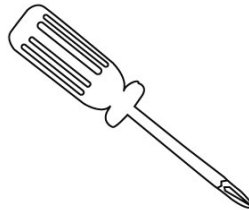

b. Philips head screw driver.

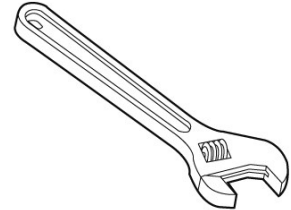

c. Shifter Spanner.

If install the faucet on the sink with three (3) connection holes, make sure themiddle diameter is bigger than 30 mm. The two (2) holes besides can be covered with long trim plate to keep it nice appearance and waterproof. Long strip ornament cover should be solely Optional Accessory.



Long strip  
ornament cover

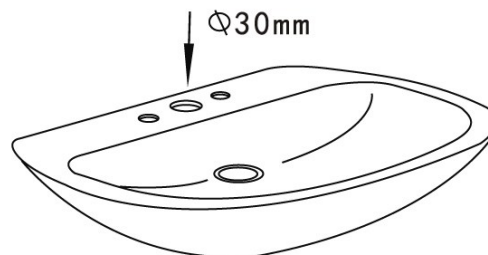

Hand basin with three(3)  
connection holes

## Installation

If installing the faucet on a sink with a single connection hole, please ensure the hole diameter is bigger than 30mm. The sink top surface to the floor surface , should be 700-800mm. Water stop valve should be installed on the left ( or right ) side of the sink. Total height from floor surface should be above 300mm.

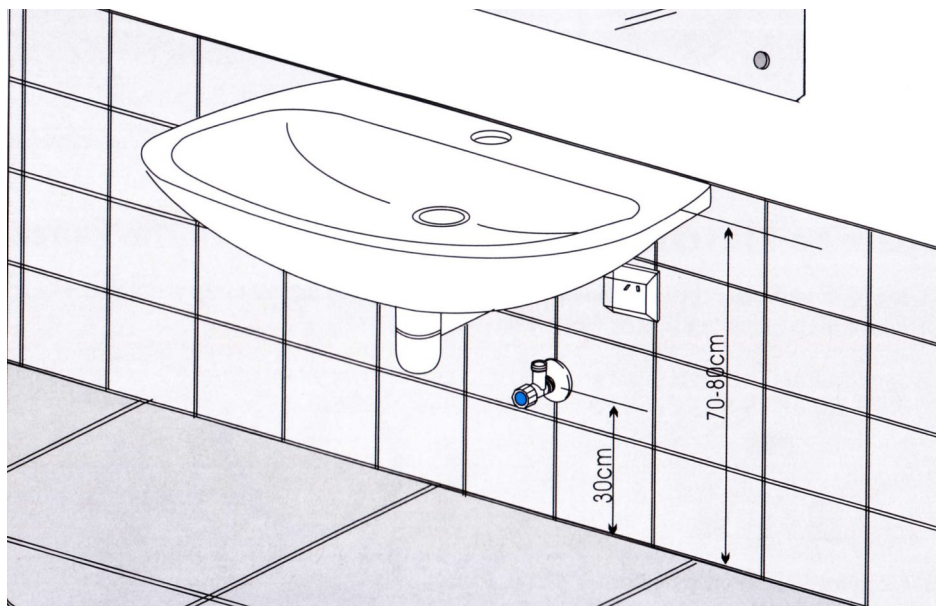

1

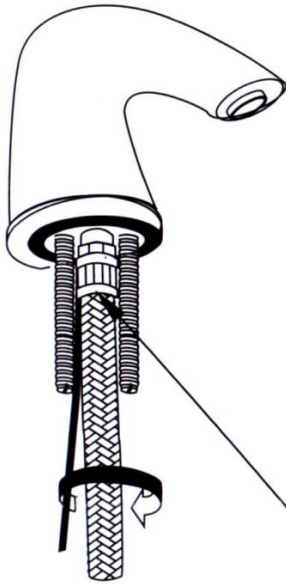

1. Insert Faucet with power wire and flexible hose into the hole of basin.

2. Insert the pipe into the water inlet aperture (at the base of the faucet) and screw it tight.

2



3

3. Adjust the position of faucet, fix with retainer and nut fasten.

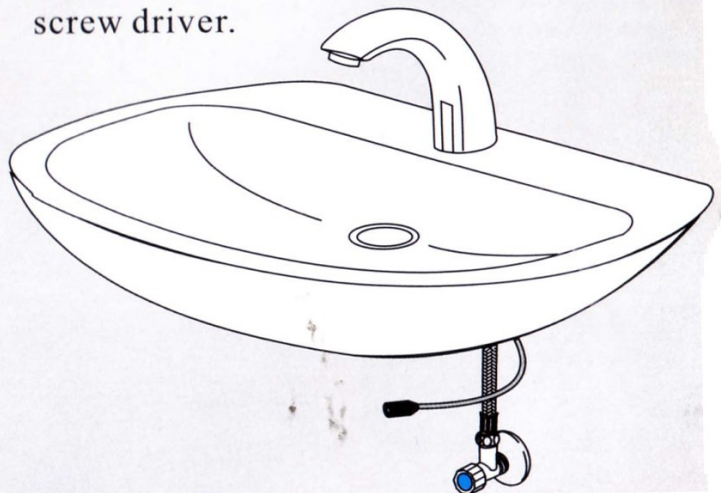
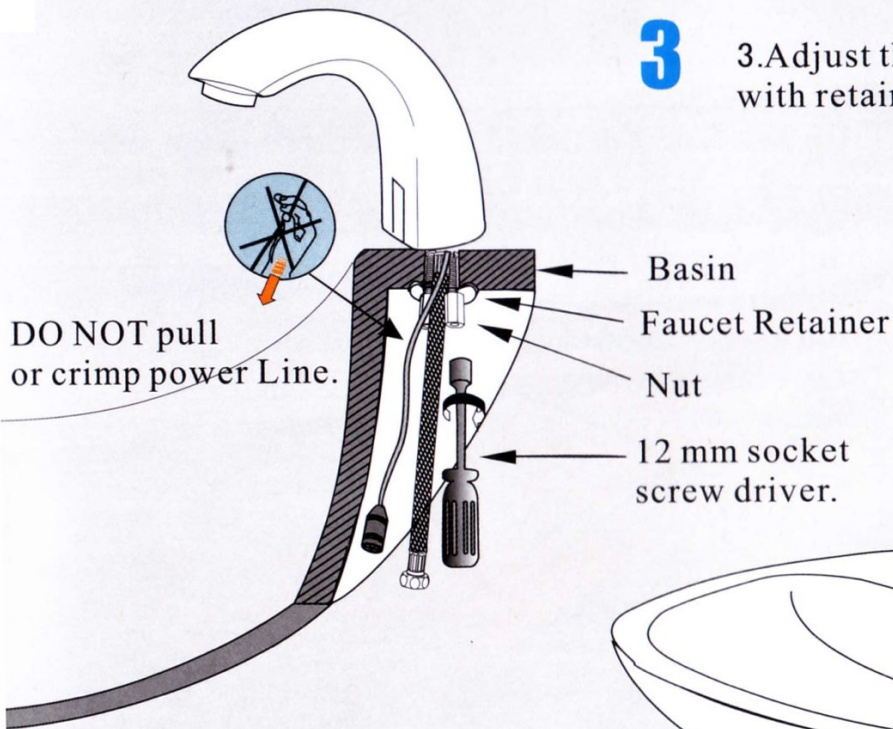



4

1. When connect to power, LED light on the sensor control flashed 3 times.

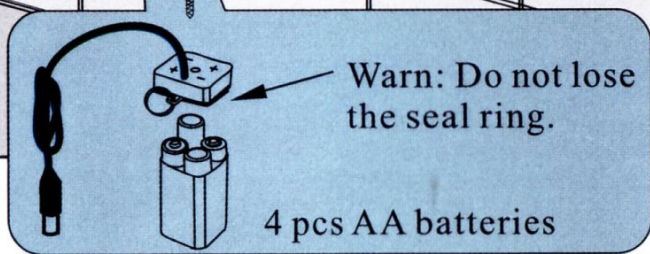
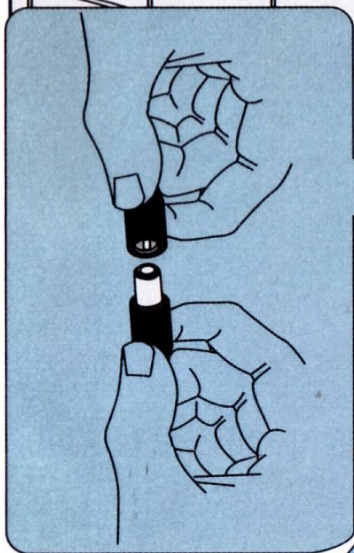

When hands are within the sensing range, the LED light will flash once, Faucet will activate. When user moves hands away Solenoid valve will shut off.

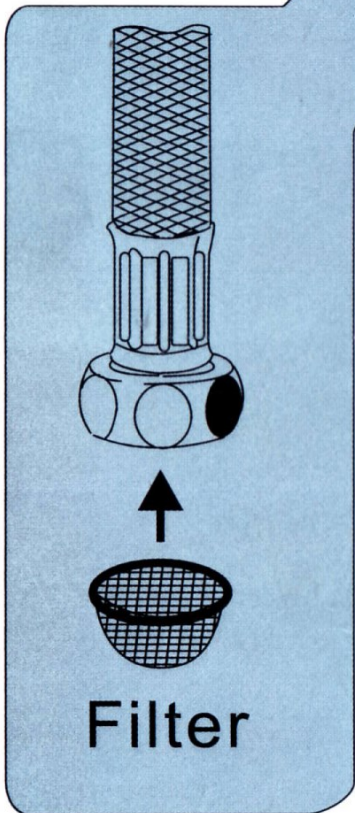

5

\* If the faucet needs to be installed on a sink with 3 connection holes, make sure the middle hole is bigger than 30mm. The two holes besides can be covered with long trim plate to keep it nice in appearance and waterproof. Long strip ornament cover is an optional accessory.



## Diagram for Install Hot & Cold Water Mixer

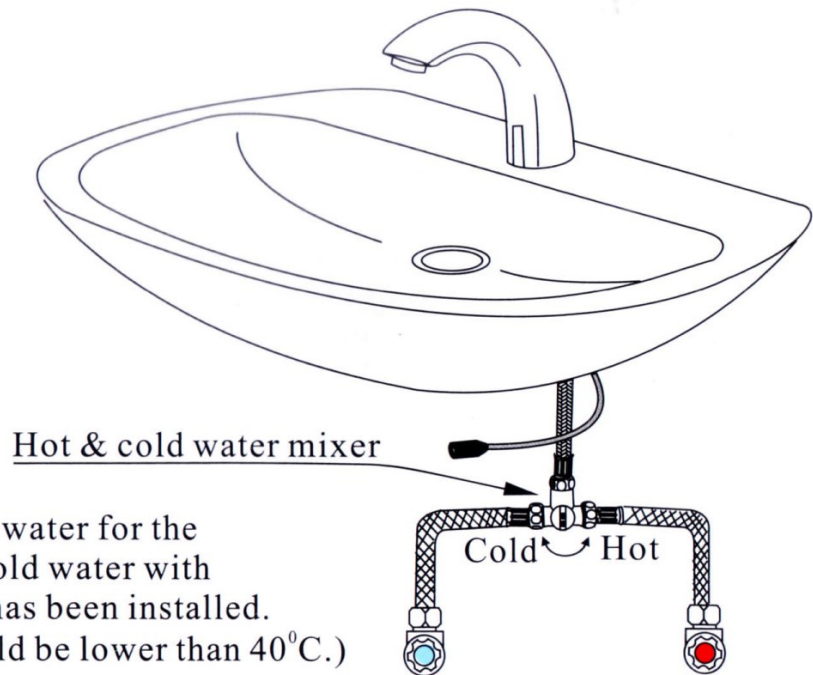

※

If want to install hot and cold water for the faucet, make sure the hot & cold water with flexible hoses and the mixer has been installed.  
(Hot water temperature should be lower than 40°C.)



## Cleaning / Maintenance

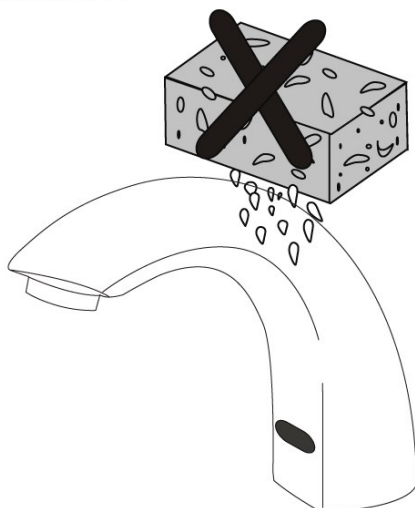

1. To keep it nice appearance, regular cleaning is essential.
2. Do not use abrasive or chemical cleaners (including chlorine bleach) to clean the Faucet, that may dull the luster and attack the chrome or special decorative finishes.
3. Wash use ONLY in soapy water, dry with clean soft cloth or towel.
4. When cleaning the bathroom tiles, should protect the Faucet from any splattering of cleaner Acids and cleaning fluids, it will discolor or remove chrome plating, also losing shining appearance.

## Trouble Shooting

Automatic sensor faucet comprises with 3 main parts, which are sensor control, solenoid valve and power transformer or battery box. If you have two (2) units of same model, you can exchange the three (3) main parts accordingly to find out the problem part and change to the new one. To do so, you need to make sure the power is supplied, water valve is opened and the filter is not choked.

1. Faucet not delivery water. Check power supply. If using battery type, replace new batteries. After that, LED indicator of the sensor control module flashed 3 times, that mean power supply is good. Put hands into sensing range, if LED indicator is always off, please change sensor control module.
2. If new batteries placed, water flows for 30 seconds and stops, not working after that. That mean sensing range is too long. Please shorten the sensing range. (Refer to sensor range adjustment.)
3. Faucet not delivery water when sensing hands. Turn off water valve, if can hear "click" sound from solenoid valve, that mean sensor control is good. Please check the filter or the solenoid valve whether is choked.
4. Faucet delivery water intermittently when no person is using or someone pass by, that mean sensing range is long, please shorten the sensing range. (refer to sensor range adjustment)
5. Faucet delivery water continuously. Solenoid valve have problem, please change solenoid valve.