





Installation Manual



AUTOMATIC SENSOR TAP HOSPITAL SPOUT—18CM



-  CAT 67910 – Chrome Plated
-  CAT 67910B – Matte Black
-  CAT 67910G – Gold Chrome Plated



Revision 10

PAGE 1

MEFE— Mitchell Engineering Food Equipment Pty Ltd

23 Storie Street Clontarf QLD 4019 Australia

www.mefe.com.au info@mefe.com.au

+61 (0)7 32834536

AU 1800 669 0006

Product Description

- With Micro- computer sensor control module, Low-consumption Micro-processor chip, stable features and strong Anti-interference function.
- Memorises adjusted sensor distance and stores into the electronic chip
- Option to use either 6 V battery pack and 240V Transformer (supplied)
- Sensor distance can be self- adjusted according to the environment.
- PCB electronic control module is double sealed and coated by high performance water proof membrane, then sealed with epoxy resin
- Faucet body is made from #59 solid brass with a superior electroplating to prevent corrosion and give a nice shiny finish
- Water saving aerator used in faucet, to prevent water splash and allow for a soft flow
- The faucet has been precisely manufactured and tested, to ensure the quality of the product reaches international standards

Technical Data

- Faucet spout material: solid brass with chrome finished
- Power supply: AC 240V or DC 6V (4pcs AA alkaline batteries)
- Battery life: 150,000 cycles
- Sensing range: 5cm to 22cm (automatic adjustable)
- Working temperature: 1 - 600C
- Water pressure: Minimum necessary water pressure 0.07Mpa - 0.7Mpa
- Supply inlet size: BSP 1/2 (DN15), male thread
- Installation diameter: single hole (32mm)
- Response time: less than 0.7 second
- Water stop protection time: 60 second
- Water flow rate: When water pressure under 0.3 Mpa less than 3 L/S



Operation:

	<p>The sensor tap will run when hands are detected. Tap will remain on for as long as hands are in range.</p> <p>The sensing range is automatically calibrated when first powered</p>
	<p>The tap will automatically switch off when hands are removed, to reactivate flow simply place hands under sensor</p>
	<p>The tap has a safety feature that will automatically switch off after more than 30 seconds of flow. to reactivate simply remove and re-apply hands. The tap is safe ,will switch off if no batteries, normally off</p>

Attention:

When the user uses the faucet for more than 60 seconds, or faucet is activated for a long period, the solenoid valve will close automatically, until the user steps away from the sensor. Sensor will reset for normal use.

Faucet Rough-In

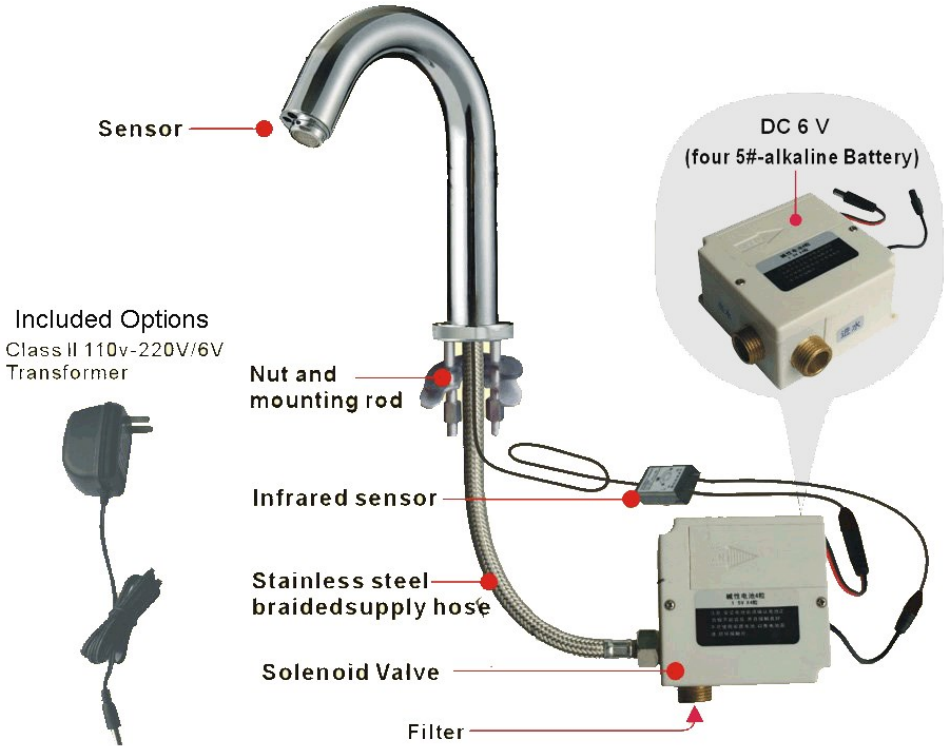

Installation Dimensions

Installation diagram

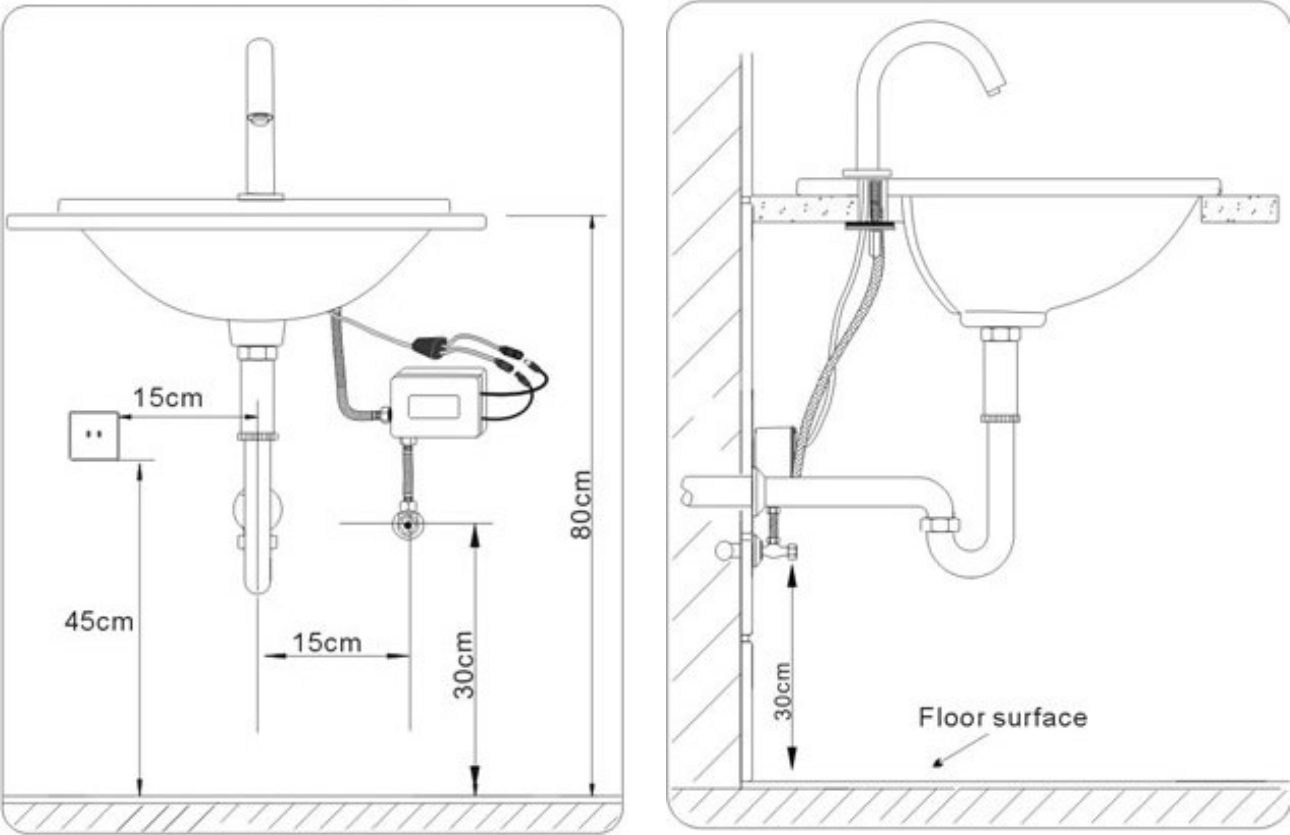

Prior to Installation

Please choose the right basin prior to installation

Warning: Sensor of the faucet must be higher than the basin or lavatory. Minimum of 15mm.

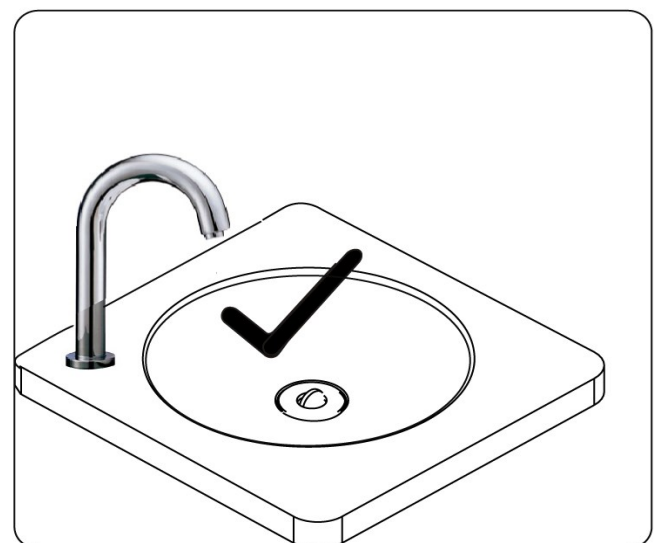
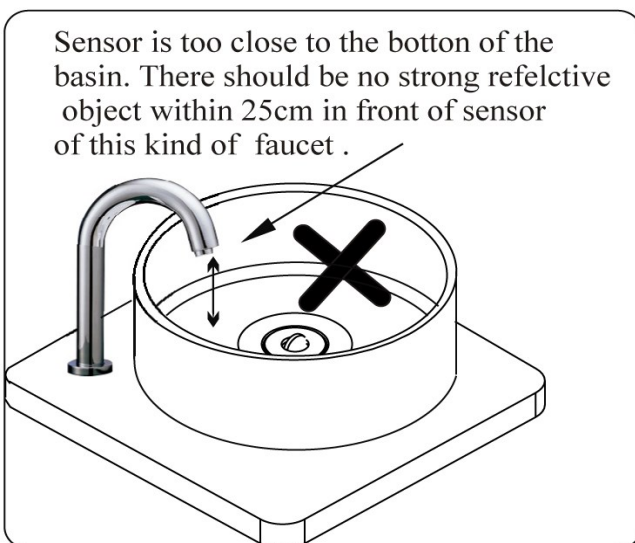
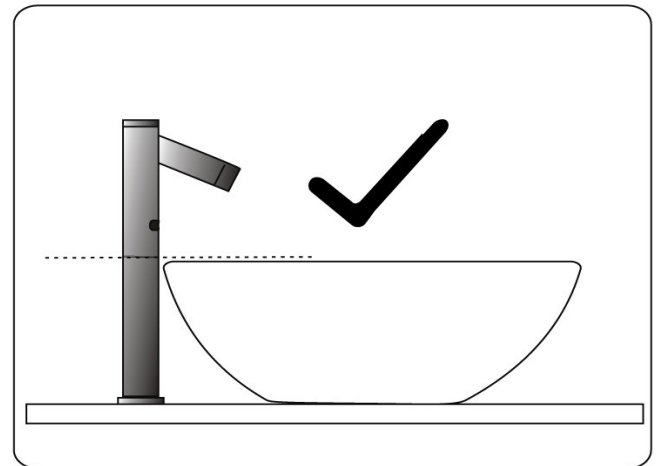
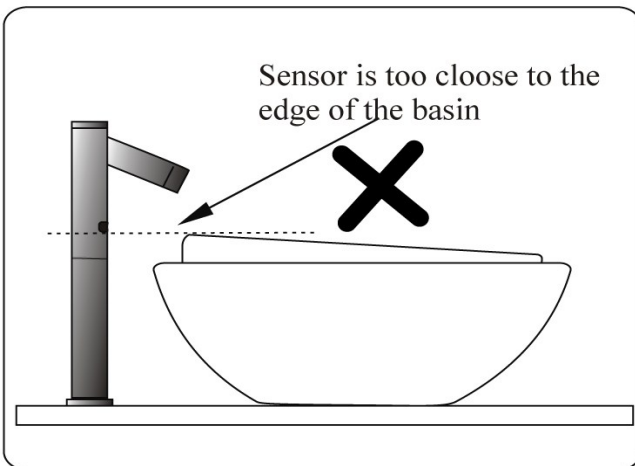
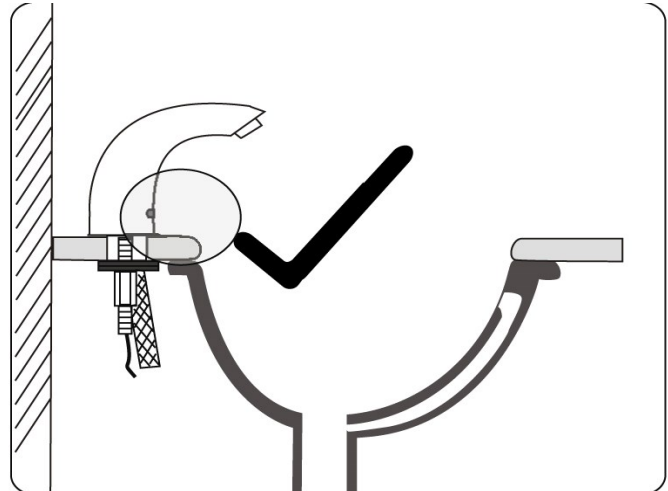
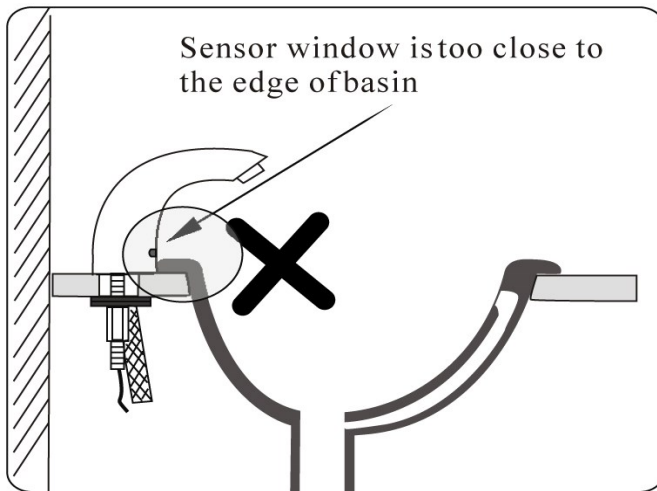

Prior to installing faucet, prepare the items listed below.

- Please choose the right basin before installation.
- Water supply pipe and water-proof socket (for electricity type).
- Hot/Cold water inlet flexible hose with 1/2 inch BSP nut on both ends. (Water temperature should be less than 40 degrees)
- Ensure all pipes are cleared of any dirt before installation.
- Installation shall be in accordance with AS/NZS3500 series of Standards

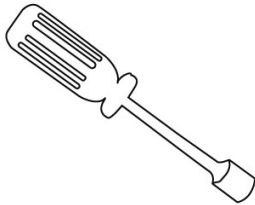

a. 12 mm socket screw driver.

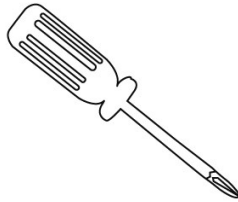

b. Philips head screw driver.

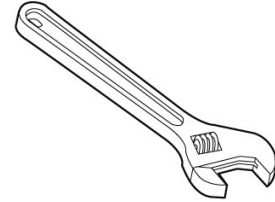

c. Shifter Spanner.

If install the faucet on the sink with three (3) connection holes, make sure the middle diameter is bigger than 30 mm. The two (2) holes besides can be covered with long trim plate to keep it nice appearance and waterproof. Long strip ornament cover should be solely Optional Accessory.

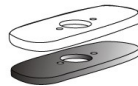

Long strip ornament cover

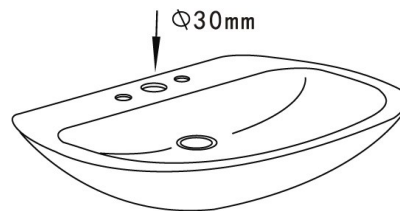

Hand basin with three(3) connection holes

- Supply stops and 20mm flex hose with DN 15 nut at both ends
- Water pipes and waterproof electricity mains (for AC type)
- If you need to adjust water temperature, please purchase cold and hot supply mixer and 2 extra 20mm flex hose with DN15 nut at both ends.
- Flush all pipe lines until water is clear before connecting.

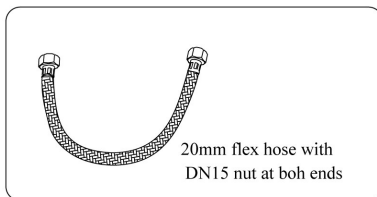

PLEASE NOTE

Once faucet has been installed, please stick one of the coloured dots provided on to the head of the faucet to allow the user to identify if water will flow cold or hot.

RED DOT—HOT WATER

BLUE DOT—COLD WATER



CAT 67M

Mixer T-Piece

Not supplied with tap ware, to be purchased separately.



Cat 67910 Automatic Faucets Exploded View

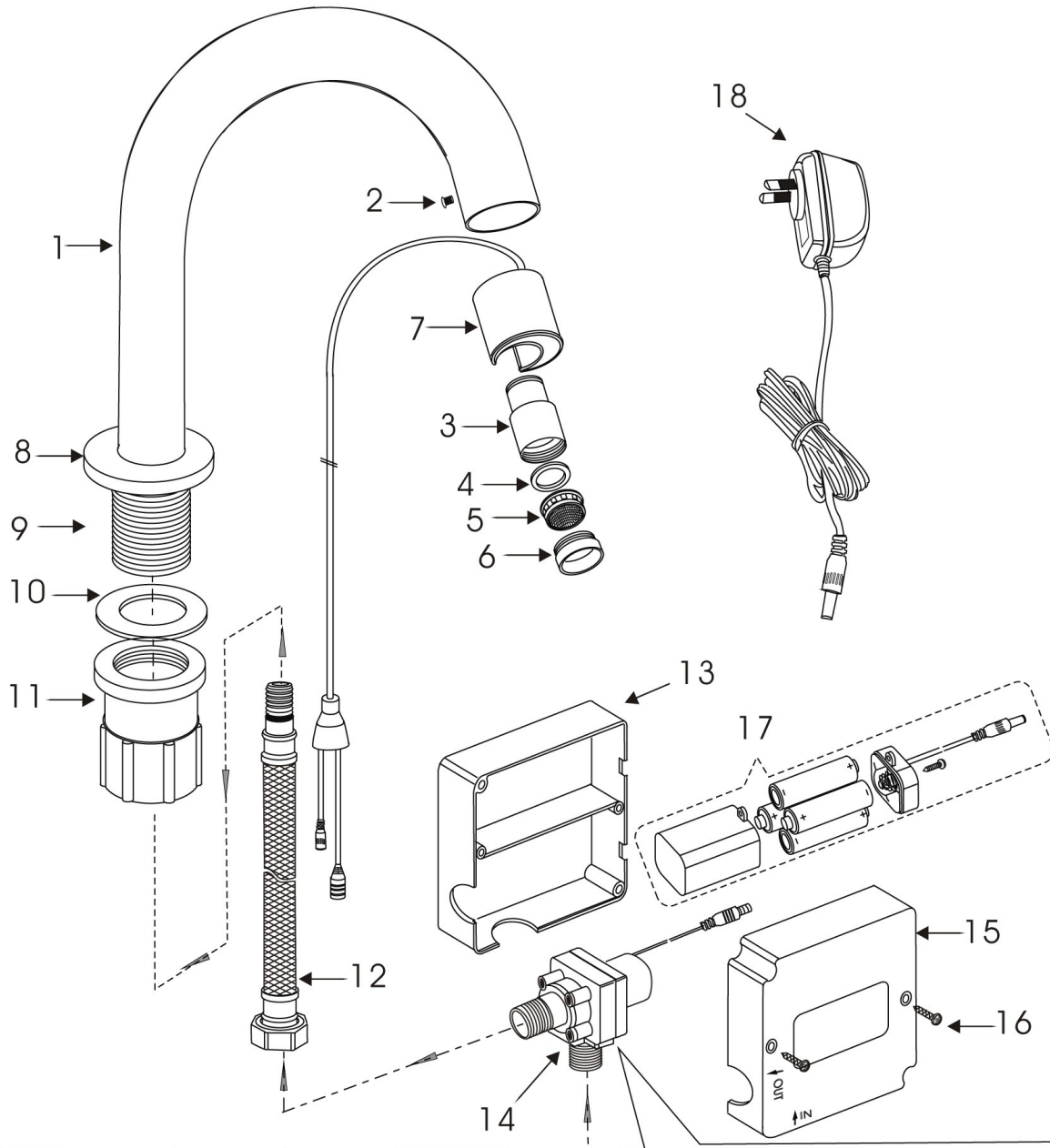

- | | |
|--|---|
| | <ul style="list-style-type: none"> 14-1, Adapter (SUS 304 Stainless) 14-2, Body Valve (POM Plastic) 14-3, Diaphragm (NBR rubber) 14-4, Diaphragm skeleton (POM Plastic) 14-5, Spring needle (SUS 304 Stainless) 14-6, seat (POM Plastic) 14-7, glue (Silicone rubber) 14-8, Core (430 Stainless) 14-9, Spring (SUS 304 Stainless) 14-10, set (POM Plastic) 14-11, Solenoid valve (Brass+iron) 14-12, cover (POM Plastic) |
|--|---|

For Black Tap add *B to the end of PART#

ITEM	PART#	DESCRIPTION	MATERIAL	ITEM	PART#	DESCRIPTION	MATERIAL
1.	679-100	Faucet Body	Brass CW602N	10.	679-109	Mat	NBR Rubber
2.	673-045	Screw	SUS 304 Stainless Steel	11.	679-110	Copper Nut	POM Plastic + Brass
3.	673-054C	Spout Adapter	Brass CW602N	12.	673-058	S/Steel Braided Hose	SUS 304 Stainless WMKA21505
4.	673-054B	Rubber Mat	NBR Rubber	13.	679-120	Housing	ABS Plastic
5.	673-054	Aerator	POM Plastic	14.	679-122	Solenoid Valve	POM Plastic WMKA21177
6.	673-054A	Spout Shell	Brass CW602N	15.	679-120	Housing	ABS Plastic
7.	679-106	Sensor	Electronic Hardware	16.	679-127	Screw	SUS 304 Stainless Steel
8.	679-107	Cover	Brass CW602N	17.	679-121	Battery Box	ABS Plastic
9.	679-108	S/Steel Bolt	SUS 304 Stainless Steel	18.	679-128	Power Adaptor	Electronic Hard- ware