

## Installation Manual



### Automatic Sensor Tap

### Deck Mounted

CAT 67917 | CAT 67917B

Revision 11

## Product Description

- This sensor tap is designed to turn on with sensor activation and off when hands are removed.
- Features a micro-computer infrared sensor control module, low consumption microprocessor chip with stable performance and high anti-interference.
- Automatically calibrates sensing range according to the environment and stores this into the electronic chip.
- A water saving aerator is used in the faucet to prevent water splash back and allow for a soft flow.
- Supplied with both AC 240V Transformer and DC 6V Battery Pack.
- The faucet has been precisely manufactured and tested, ensuring the quality of the product satisfies international standards.

## Pre-Install Instructions

Please choose an appropriate basin before installation, avoid basins with strong reflective surfaces.

Please ensure all pipes have been flushed for at least 60 seconds and are clear of dirt and impurities (water must be clear).

Installation must be in accordance with the National Plumbing and Drainage standard – AS/NZS 3500.

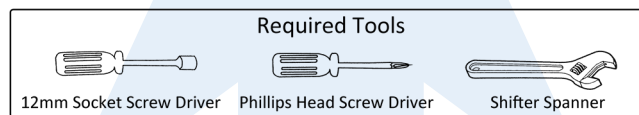

## Sensing Range

The sensor tap will automatically calibrate the sensing range when first connected to power. Please ensure the tap has been installed in the correct and final position before connecting to power. When connected to power the sensing light will flash indicating it is in programming mode, please do not interfere or obstruct for at least 60 seconds.

## Specifications

<b>Power</b>	AC 240V or DC 6V 4 x AA alkaline batteries (batteries not supplied)	<b>Installation Diameter</b>	Single hole (32mm)
<b>Battery Life</b>	150,000 cycles	<b>Response Time</b>	Less than 0.7 seconds
<b>Sensing Range</b>	Default 5 to 22cm (auto adjusts) Reprogrammed with remote achieves min 0 to 5 or max 0 to 20cm*	<b>Water Stop Protection (Auto Shut Off)</b>	Approx. 30 seconds
<b>Working Temperature</b>	1°C - 60°C	<b>Flow Rate</b>	Less than 3 L/s at 0.3Mpa
<b>Working Pressure</b>	0.07Mpa—0.7Mpa	<b>Ambient Humidity</b>	95% or less
<b>Inlet Size</b>	BSP 1/2" (DN15) male thread	<b>Faucet Body Material</b>	304 Stainless Steel

\*To reprogram sensing range use optional remote 673-100R.



### WaterMark Certified

Australia and New Zealand WaterMark certified with approved licence number WM-022559.



### 6 Star WELS Rating

This guarantees that the product is in accordance with the standard set under the National Water Efficiency Labelling and Standards and has the highest possible water efficiency rated 6 Stars. Licence number 1718.



### DDA Compliant

Suitable for use for AS 1428.1 design and access requirements when installed in reference to AS 1428.1 2009 Amendment 1 and the intent of the Disability Discrimination Act (DDA).

## Choosing the Correct Basin

### IMPORTANT:

Please avoid stainless steel and other highly reflective basins as these reflections can cause interference with the sensor.

Warning: Sensor of the faucet must be higher than the basin or lavatory. Minimum of 15mm.

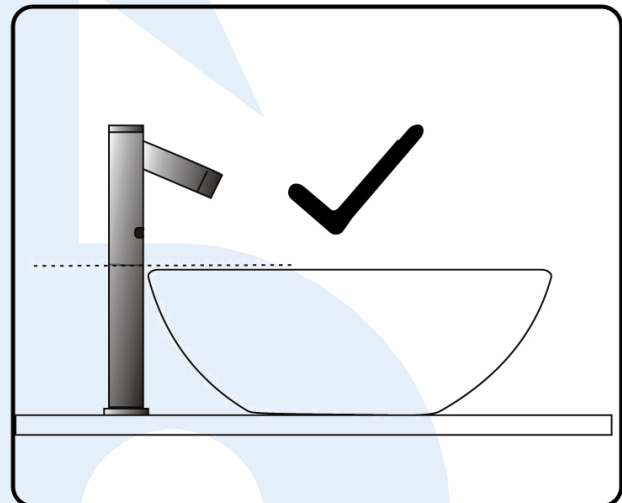
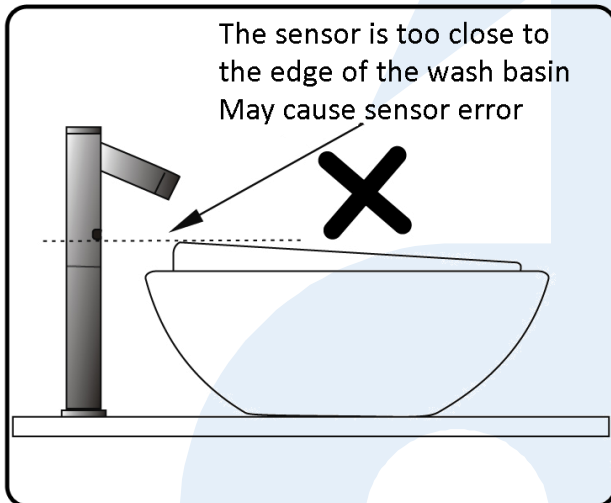
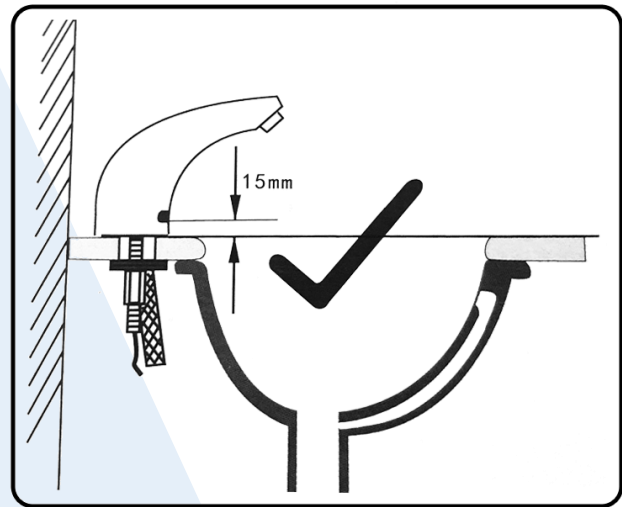
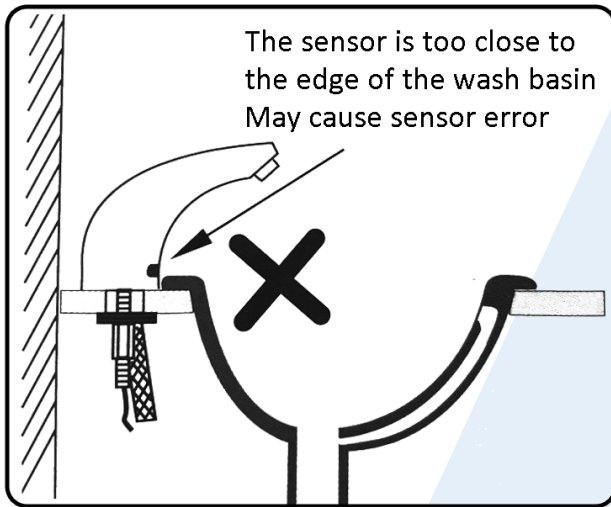

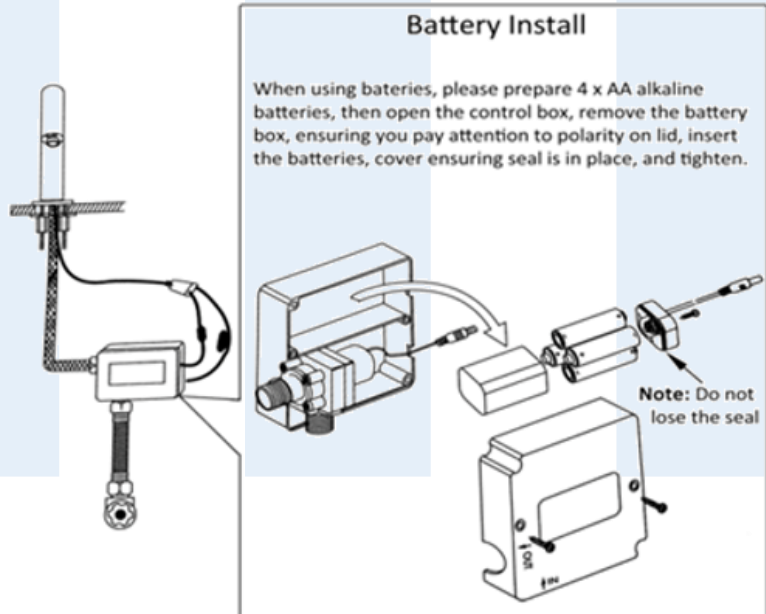
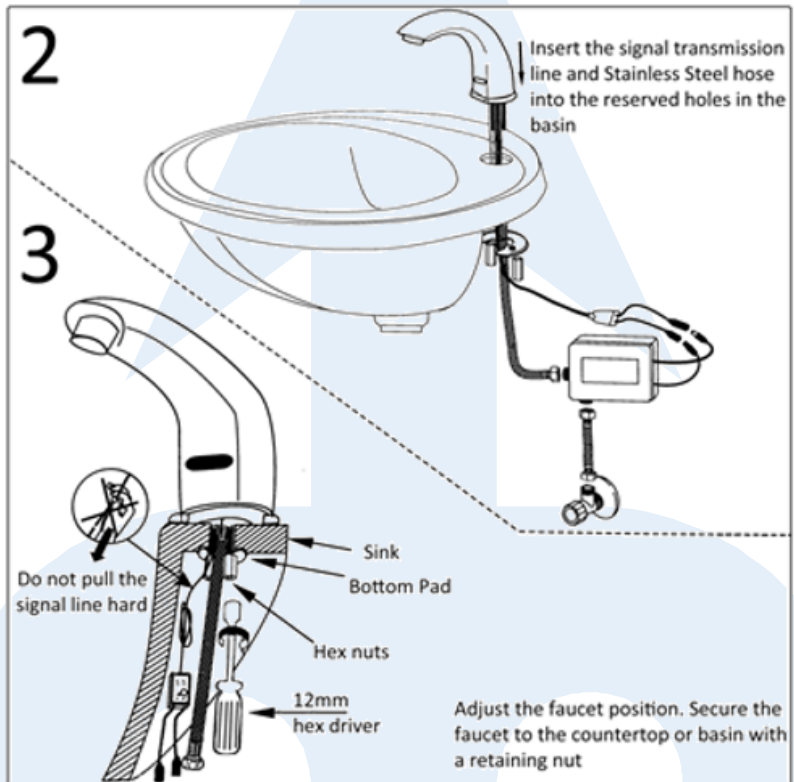
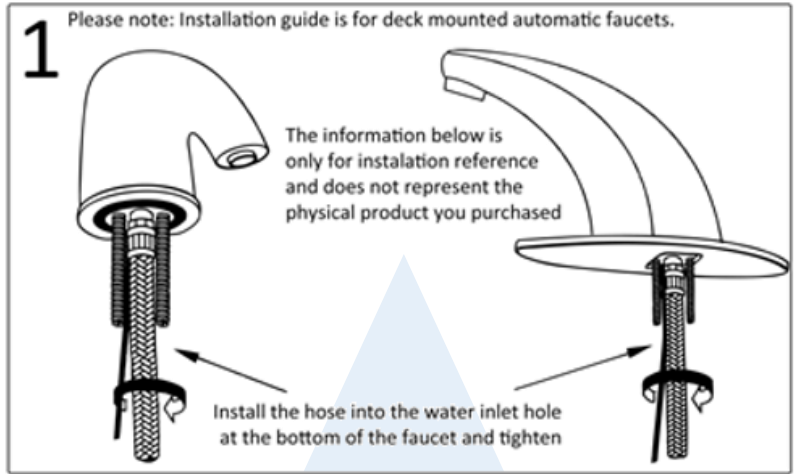

# 4

Pay attention to the direction of the solenoid valve plug, **do not** insert in reverse

1. Ensure there is a shut off valve installed at the wall connection.
2. Fix the housing box to the wall.
3. Connect the other end of the hose coming from the faucet body to the water outlet of the control box.
4. Use a 20cm long hose with 1/2" nut on both sides. Connect the water outlet of the shut off valve, and the water inlet of the control box.
5. Insert the sensor cable into the socket on the control box.
6. When the power is turned on, the LED on the sensor controller will flash 3 times.

40cm  
Ground

# 5

Place your hand under the water outlet and the solenoid valve will make a click. The LED in the sensor will flash. Water is activated. Remove hand and water will stop. Place supplied red or blue dot on head of faucet to identify hot or cold water

Optional: Hot and Cold Mixer

- 2 x Watermarked Braided Hoses (flexible) with a DN15 nut on both ends
- (673-058L 120cm / 673-058 100cm)
- 1 x Watermarked Mixer Valve (CAT 67 M2)

Cold Hot

G1/2 G1/2

## Fault Check

Our sensor tap range is primarily divided into three components: the sensor, the solenoid valve, and the power supply. The solenoid valve and power supply are universal and interchangeable parts across our range of same type taps. The sensor is specific to each spout type.

If you have other sensor taps or spare parts available it can be helpful to trouble shoot by swapping parts until the faulty part is identified.

Issue	Cause
<b>No water flow</b>	<b>Check the power supply:</b> if using batteries, carefully check the correct polarity of the batteries and replace. The sensor light should flash indicating the tap is entering programming mode.
<b>No water flow</b>	<b>Check the sensor:</b> After confirming power is OK, if the sensor light does not flash, replace the sensor.
<b>No water flow</b>	<b>Check the solenoid valve:</b> place your hands under the faucet, you should hear a click of the solenoid valve indicating the sensor is working normally. This means water is not supplied or unable to flow. Check the solenoid valve for obstruction—the solenoid diaphragm may be blocked. Opening and cleaning the solenoid may be necessary, or replace the solenoid valve.
<b>Low water flow</b>	<b>Check the solenoid valve:</b> A leaking faucet with a constant slow flow indicates the diaphragm is not sealing due to debris or it may be cracked or torn. Replace the diaphragm or the complete solenoid valve.
<b>Intermittent water flow</b>	<b>Check the sensing range:</b> This is most likely caused by a failure to program sensing range correctly due to interference from a reflective basin. We recommend you remove power for 2 minutes, then reconnect and allow the sensor to adjust to a short sensing range. It can be beneficial to place cardboard at the bottom of the basin when recalibrating the sensing range to remove interference from strong reflections.
<b>Water does not stop flowing</b>	<b>Check the solenoid valve:</b> If the faucet does not stop flowing it may be that the solenoid valve is faulty and should be replaced. The diaphragm is not sealing due to debris or it may be cracked or torn. Replace the diaphragm or the complete solenoid valve.

## Cleaning and Maintenance

Regular cleaning is essential to keep your tap looking its best.

**Do not** rinse the control box with water.

**Do not** use abrasive or chemical cleaners (including chlorine clean to clean the faucet as this can dull lustre and finish of the tap).

**Wash only** in soap water and dry with a clean soft towel or microfibre cloth.

When cleaning the general area please ensure you protect the faucet from any cleaning acids or fluids as this can discolour or remove the chrome plating where applicable.

The filter screen on the solenoid valve inlet should be cleaned regularly to avoid excessive blockage and obstruction caused by impurities resulting in low water flow.



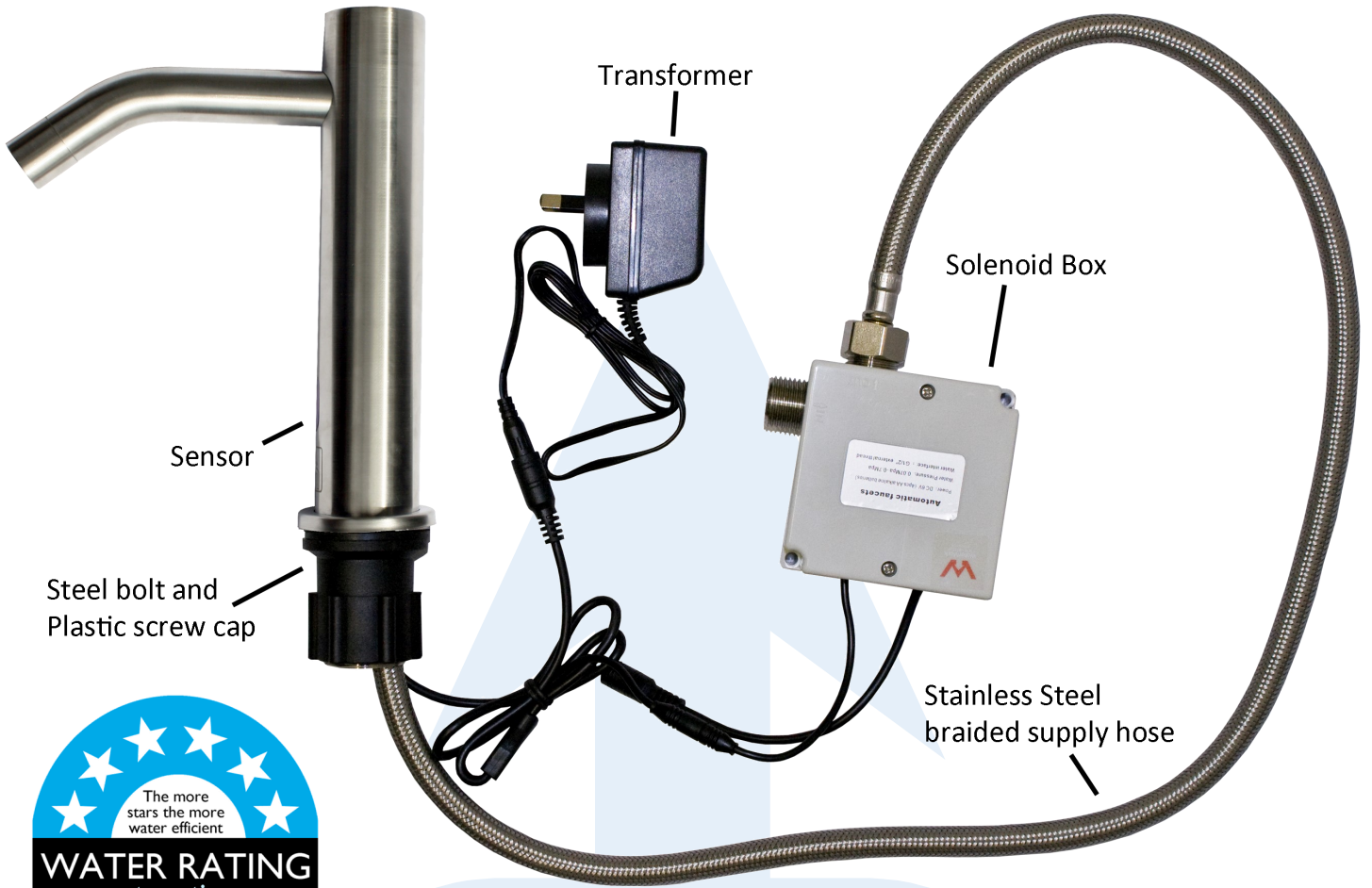

The more stars the more water efficient

**WATER RATING**  
www.waterrating.gov.au

**5.5** litres per minute

In accordance with AS/NZS 6400

**Licence No. 1718**  
Mitchell Engineering Food Equipment Pty Ltd

**WaterMark**  
WM - 022559  
AS/NZS 3718

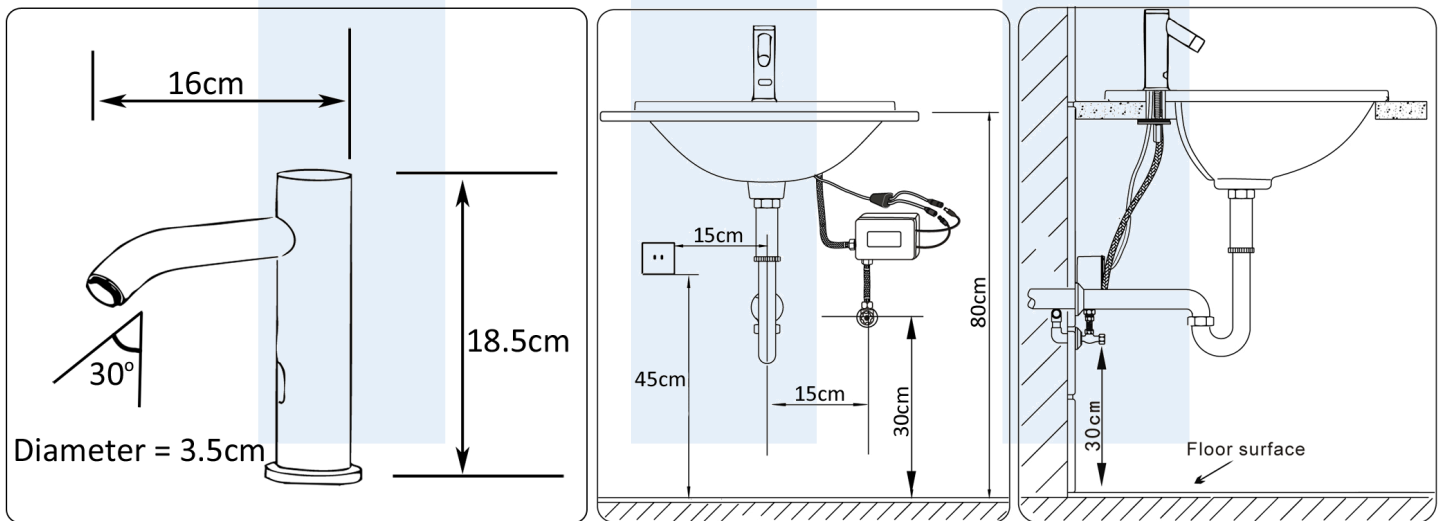

# CAT 67917 Automatic Faucet Exploded View

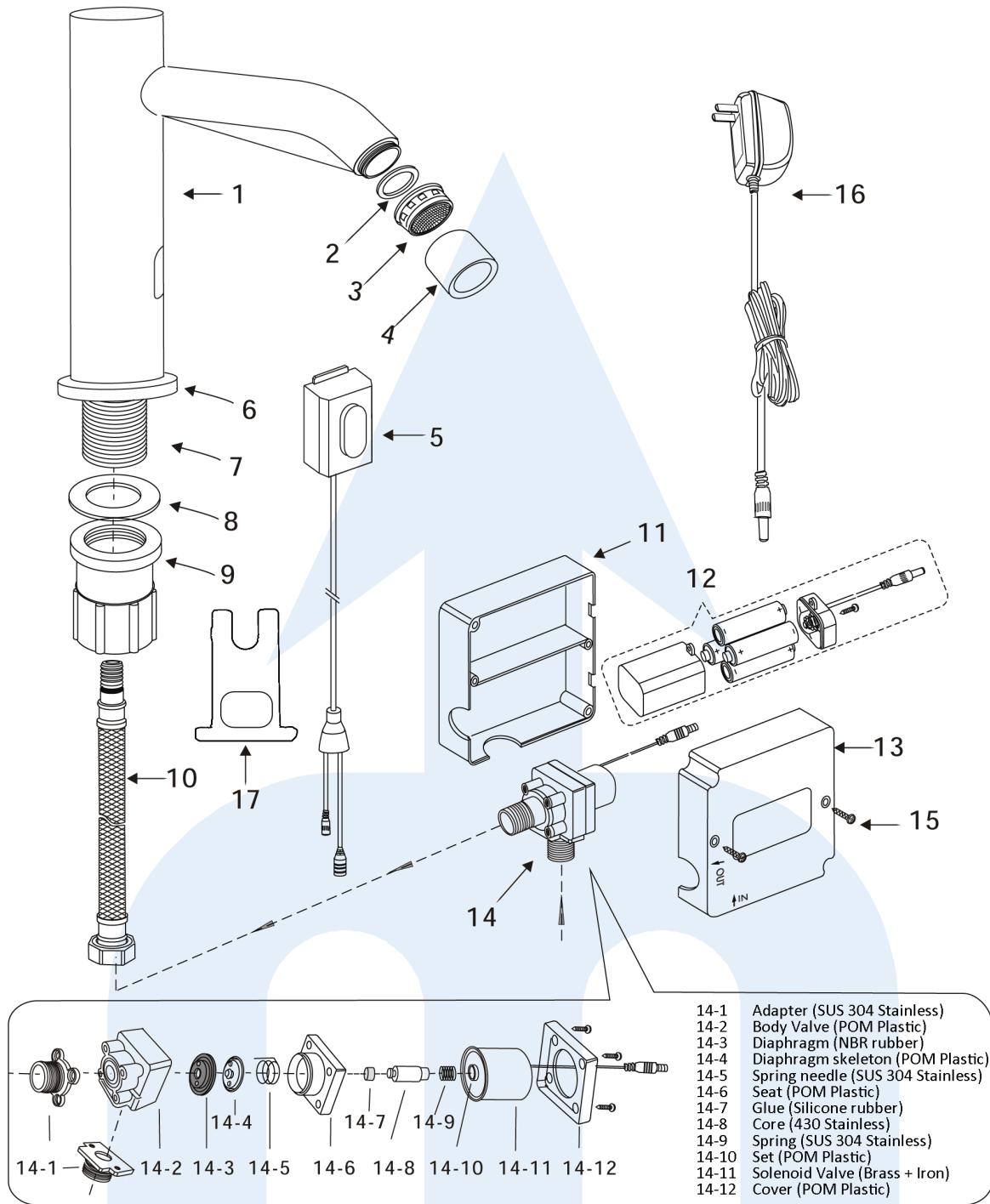

No.	Part #	Description	Material	No.	Part #	Description	Material
1.	679-170	Faucet Body	SUS 304 Stainless Steel	10.	673-058	Braided Hose	SUS 304 Stainless WMKA21505
2.	679-172	Rubber Mat	NBR Rubber	11.	679-120	Housing	ABS Plastic
3.	679-173	Aerator	POM Plastic	12.	679-121	Battery Box	ABS Plastic
4.	679-171	Spout Shell	SUS 304 Stainless Steel	13.	679-120	Housing	ABS Plastic
5.	679-131	Sensor	Electronic Hardware	14.	679-122	Solenoid Valve	POM Plastic + SUS 304 S/Steel
6.	679-107	Cover	SUS 304 Stainless Steel	15.	679-038	Screw	SUS 304 Stainless Steel
7.	679-108	S/Steel Bolt	SUS 304 Stainless Steel	16.	679-128	Power Adaptor	Electronic Hardware
8.	679-109	Mat	NBR Rubber	17.	679-129	Sensor Lock	POM Plastic
9.	679-110	Copper Nut	POM Plastic + Brass	18.	N/A	N/A	N/A