

Sensor Tap – All-In-One

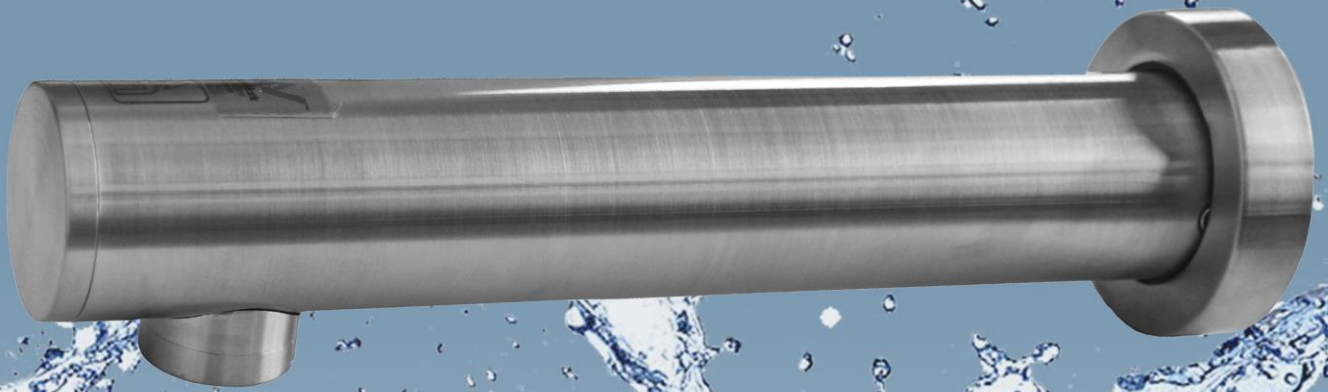

The more stars the more water efficient

WATER RATING
www.waterrating.gov.au

5.0 litres per minute

In accordance with AS/NZS 6400

Licence No. 1718
Mitchell Engineering Food
Equipment Pty Ltd

WaterMark
WM-022559
AS/NZS 3718



CAT 673031

All-in-one – Stainless Steel Wall Mounted

Features

Up to 70% water saved
 Hygienic with zero cross contamination
 Touch free and accessible activation
 "Plug and play" digital infrared sensor technology
 Sensing range automatically adjusts to your environment
 Easy installation and supplied with everything required, replaces existing ½" connections
 Fully sealed all-in-one unit, no external components or wiring, 4 x AA batteries

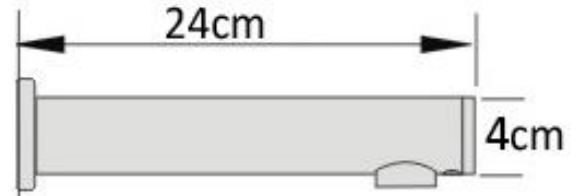

Dimensions

Spout – 24cm long
 Tap: 6 x 24 x 4cm, 0.7kg
 Boxed: 27 x 8 x 8cm, 0.8kg



Includes

All-in-one unit (solenoid valve, battery housing & brass housing)
 Instruction manual

Specifications

Wall Mounted
 Stainless Steel
 Fully sealed (all-in-one unit)
 Standard ½" Connection
 10cm Pre-set Sensing Range
 Water Pressure: 0.07-0.7Mpa

Available Finishes

-  CAT 673031 – Chrome Plated
-  CAT 673031B – Matte Black

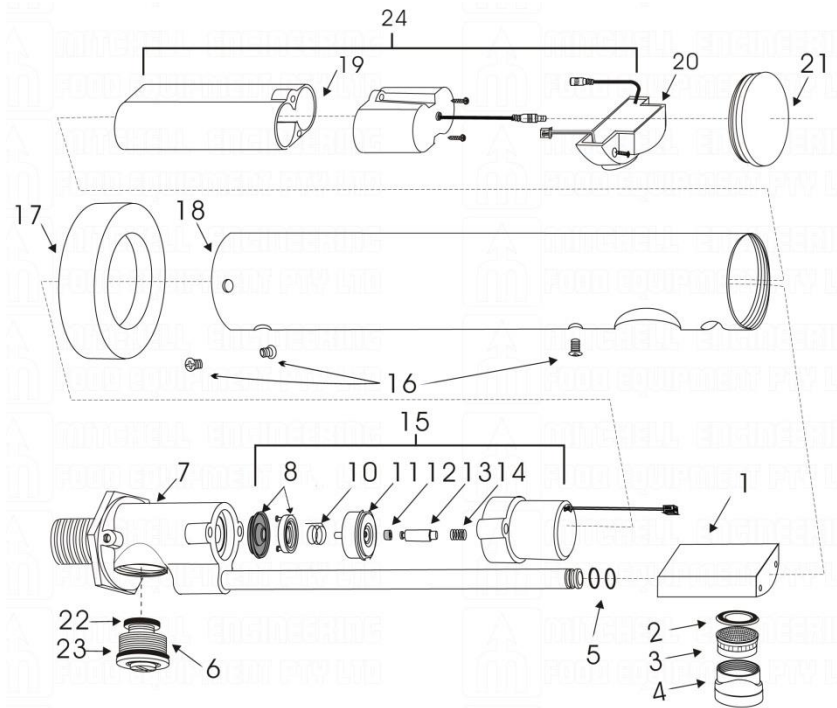

MEFE Sensor Taps are WaterMark certified and have been awarded 6 Stars, the highest WELS water efficiency rating. This signifies that our taps are eco-friendly and of the highest quality being AUS and NZ certified. Our range is DDA compliant when installed in accordance with AS 1428.1 2009.



1800 669 006
info@mefe.com.au www.mefe.com.au
 Tel: 07 3283 4536 Fax: 07 3283 4482



Sensor Tap - Tube Design



The more stars the more water efficient

WATER RATING
www.waterrating.gov.au

4.5 litres per minute

In accordance with AS/NZS 6400

Licence No. 1718
Mitchell Engineering Food Equipment Pty Ltd



WaterMark
WM-022559
AS/NZS 3718



MEFE

CAT 67305

Tube Design - Chrome Plated

Wall Mounted

Features

Up to 70% water saved
Hygienic with zero cross contamination
Touch free and accessible activation
"Plug and play" digital infrared sensor technology
Sensing range automatically adjusts to your environment
Easy installation and supplied with everything required, replaces existing 1/2" connections
No electrical wiring required, 4 x AA batteries or 240V transformer



Includes

Tube spout with fitted sensor
Solenoid box (fitted solenoid valve and battery housing, batteries not supplied)
Optional 240V transformer
Braided hose
Instruction manual

Specifications

Wall Mounted
Chrome Plated
Standard 1/2" Connection
10cm Pre-set Sensing Range
Water Pressure: 0.07-0.7Mpa

Available Finishes

-  CAT 67305 - Chrome Plated
-  CAT 67305B - Matte Black
-  CAT 67305G - Gold

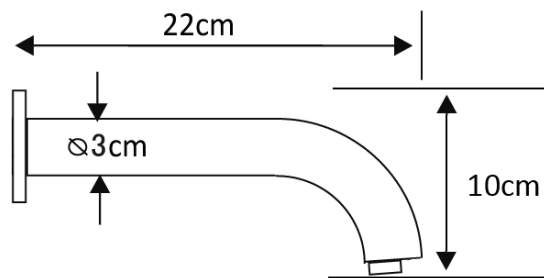

Dimensions

Tube spout - 22cm long
Tap: 10 x 22 x 3cm, 0.5kg
Boxed: 28 x 22 x 9cm, 1.4kg

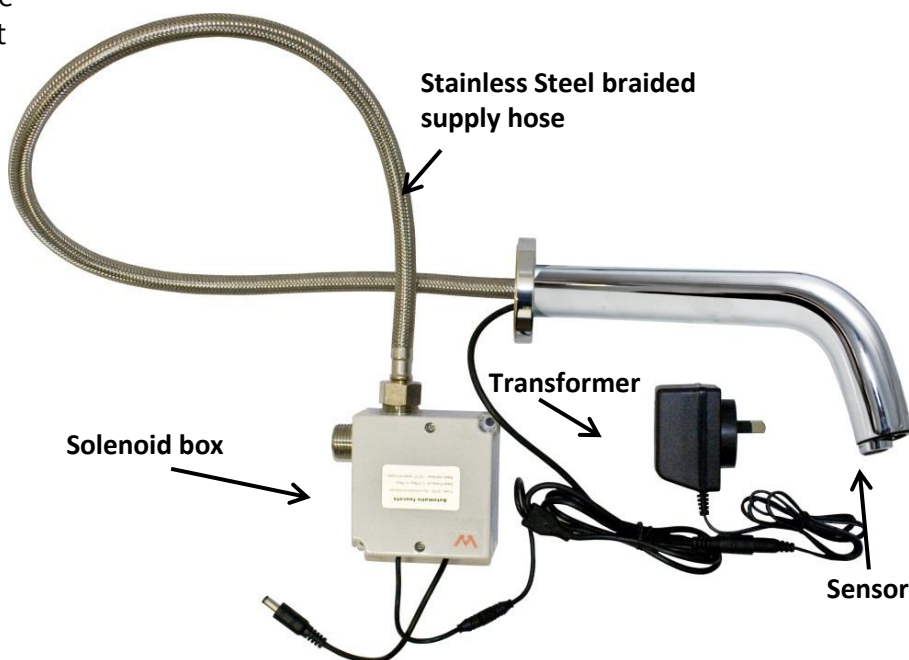

MEFE Sensor Taps are WaterMark certified and have been awarded 6 Stars, the highest WELS water efficiency rating. This signifies that our taps are eco-friendly and of the highest quality being AUS and NZ certified. Our range is DDA compliant when installed in accordance with AS 1428.1 2009.



1800 669 006
info@mefe.com.au www.mefe.com.au
Tel: 07 3283 4536 Fax: 07 3283 4482



Sensor Tap – Hospital Spout 18cm



The more stars the more water efficient

WATER RATING
www.waterrating.gov.au

4.5 litres per minute

In accordance with AS/NZS 6400

Licence No. 1718
Mitchell Engineering Food Equipment Pty Ltd



WaterMark
WM-022559
AS/NZS 3718



MEFE

CAT 67910

Hospital Spout 18cm - Chrome Plated

Deck Mounted

Features

Up to 70% water saved
Hygienic with zero cross contamination
Touch free and accessible activation
"Plug and play" digital infrared sensor technology
Sensing range automatically adjusts to your environment
Easy installation and supplied with everything required, replaces existing 1/2" connections
No electrical wiring required, 4 x AA batteries or 240V transformer



Includes

Hospital spout with fitted sensor
Solenoid box (fitted solenoid valve and battery housing, batteries not supplied)
Optional 240V transformer
Braided hose
Instruction manual

Specifications

Deck Mounted
Chrome Plated
Standard 1/2" Connection
10cm Pre-set Sensing Range
Water Pressure: 0.07-0.7Mpa

Available Finishes

-  CAT 67910 – Chrome Plated
-  CAT 67910B – Matte Black
-  CAT 67910G – Gold

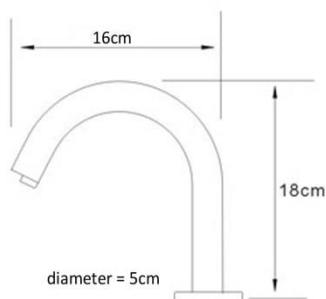

Dimensions

Hospital Spout - 18 cm high
Tap: 18 x 16 x 5 cm, 0.5 kg
Boxed: 28 x 22 x 10 cm, 1.3 kg

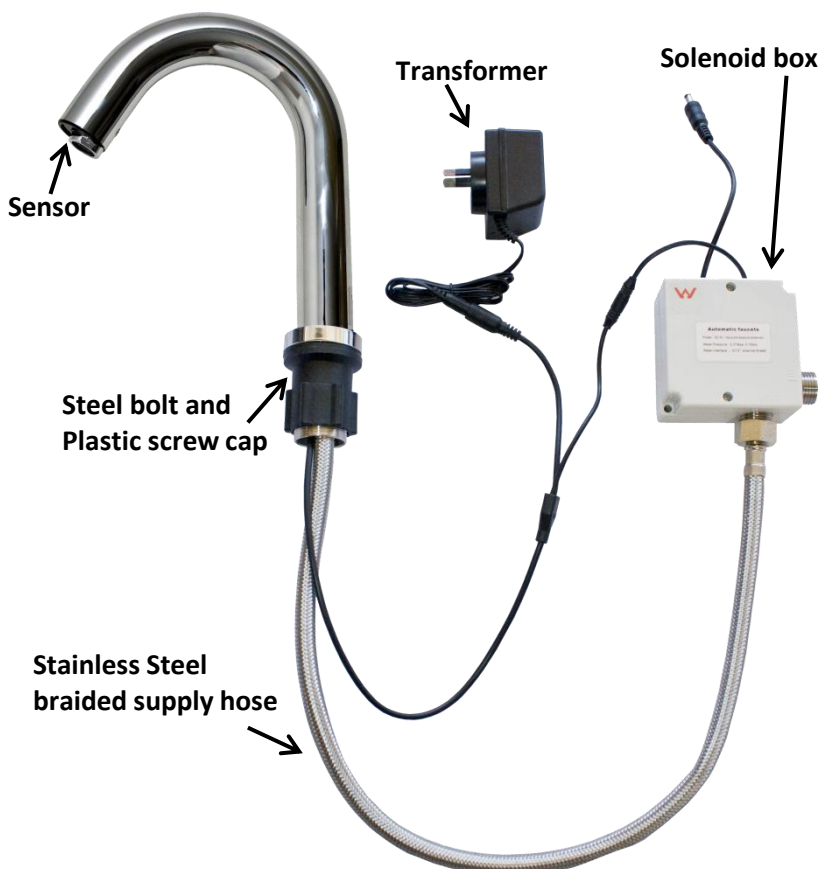

MEFE Sensor Taps are WaterMark certified and have been awarded 6 Stars, the highest WELS water efficiency rating. This signifies that our taps are eco-friendly and of the highest quality being AUS and NZ certified. Our range is DDA compliant when installed in accordance with AS 1428.1 2009.

Sensor Tap - Hospital Spout 32cm



The more stars the more water efficient

WATER RATING
www.waterrating.gov.au

4.5 litres per minute

In accordance with AS/NZS 6400

Licence No. 1718
Mitchell Engineering Food
Equipment Pty Ltd



CAT 6791032

Hospital Spout 32cm - Chrome Plated

Deck Mounted

Features

Up to 70% water saved
Hygienic with zero cross contamination
Touch free and accessible activation
"Plug and play" digital infrared sensor technology
Sensing range automatically adjusts to your environment
Easy installation and supplied with everything required, replaces existing ½" connections
No electrical wiring required, 4 x AA batteries or 240V transformer



Includes

Hospital spout with fitted sensor
Solenoid box (fitted solenoid valve and battery housing, batteries not supplied)
Optional 240V transformer
Braided hose
Instruction manual

Specifications

Wall Mounted
Chrome Plated
Standard ½" Connection
10cm Pre-set Sensing Range
Water Pressure: 0.07-0.7Mpa

Available Finishes

-  CAT 6791032 – Chrome Plated
-  CAT 6791032B – Matte Black
-  CAT 6791032G – Gold

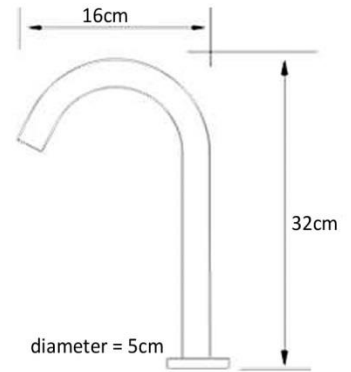

Dimensions

Hospital Spout - 32cm high
Tap: 32 x 16 x 5cm, 0.6kg
Boxed: 42 x 22 x 10cm, 1.5kg

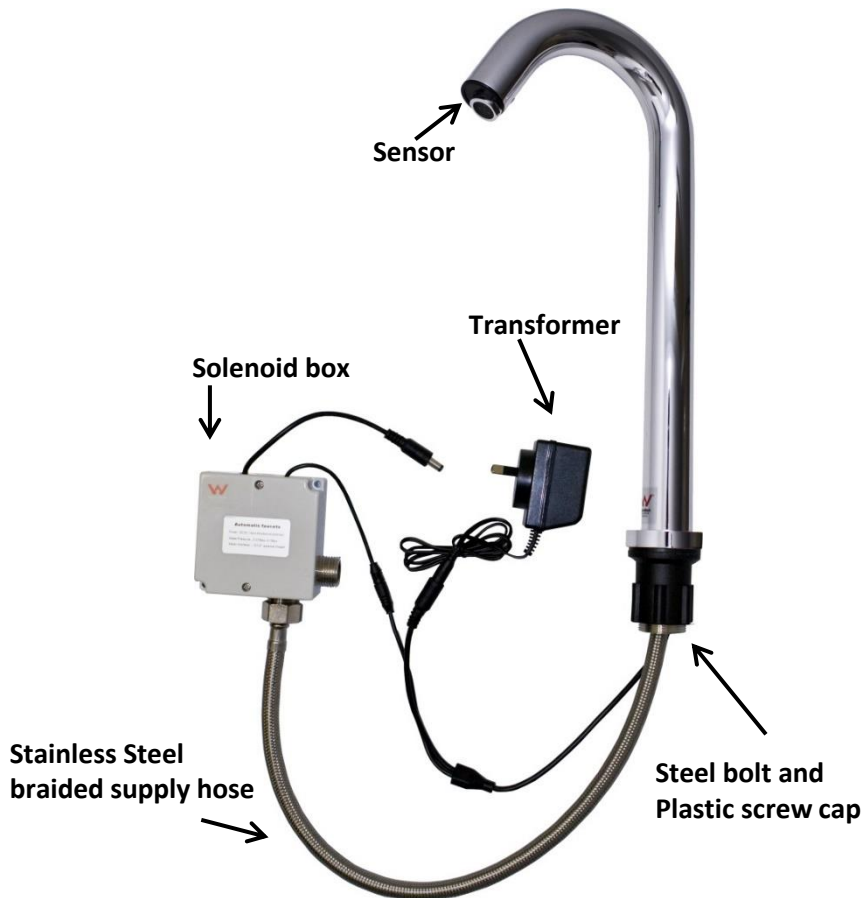

MEFE Sensor Taps are WaterMark certified and have been awarded 6 Stars, the highest WELS water efficiency rating. This signifies that our taps are eco-friendly and of the highest quality being AUS and NZ certified. Our range is DDA compliant when installed in accordance with AS 1428.1 2009.



1800 669 006
info@mefe.com.au www.mefe.com.au
Tel: 07 3283 4536 Fax: 07 3283 4482



Sensor Tap - Classic Curve Neck

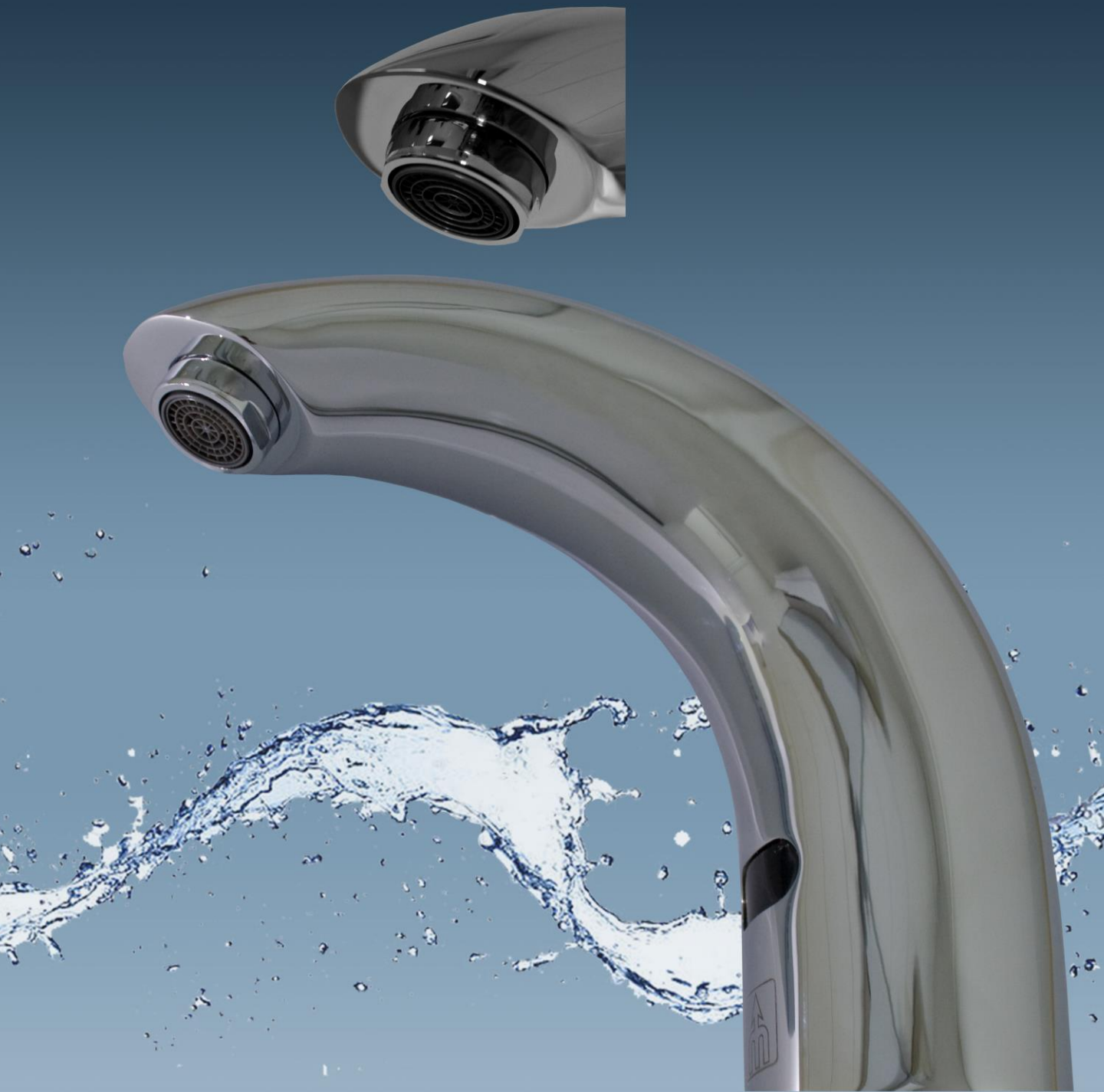

In accordance with AS/NZS 6400

Licence No. 1718

Mitchell Engineering Food
Equipment Pty Ltd



CAT 67911

Classic Curve Neck - Chrome Plated Deck Mounted

Features

Up to 70% water saved
Hygienic with zero cross contamination
Touch free and accessible activation
"Plug and play" digital infrared sensor technology
Sensing range automatically adjusts to your environment
Easy installation and supplied with everything required, replaces existing 1/2" connections
No electrical wiring required, 4 x AA batteries or 240V transformer



Includes

Curve spout with fitted sensor
Solenoid box (fitted solenoid valve and battery housing, batteries not supplied)
Optional 240V transformer
Braided hose
Instruction manual

Specifications

Deck Mounted
Chrome Plated
Standard 1/2" Connection
5 - 22cm Sensing Range
Water Pressure: 0.07-0.7Mpa

Available Finishes

-  CAT 67911 - Chrome Plated
-  CAT 67911B - Matte Black

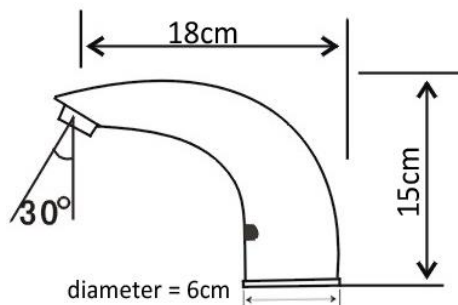

Dimensions

Curve Neck Spout - 15cm high
Tap: 15 x 18 x 6cm, 1.2kg
Boxed: 28 x 22 x 9cm, 2.1kg

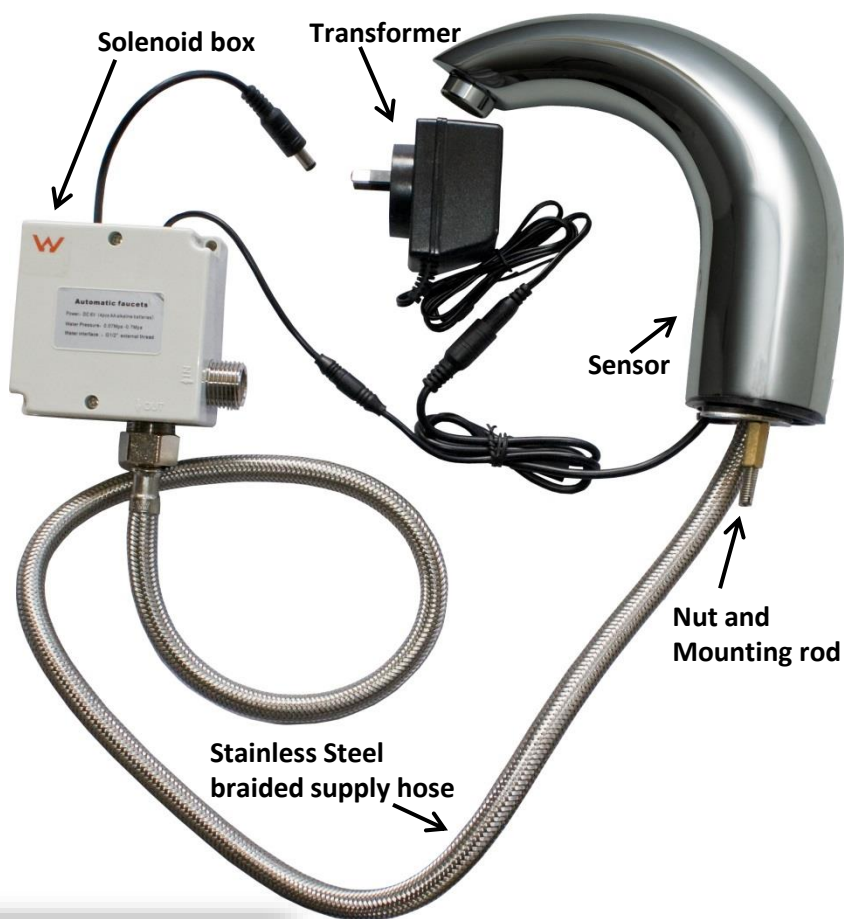

MEFE Sensor Taps are WaterMark certified and have been awarded 6 Stars, the highest WELS water efficiency rating. This signifies that our taps are eco-friendly and of the highest quality being AUS and NZ certified. Our range is DDA compliant when installed in accordance with AS 1428.1 2009.

Sensor Tap – Hot & Cold Mixer



The more stars the more water efficient

WATER RATING
www.waterrating.gov.au

5.0 litres per minute

In accordance with AS/NZS 6400

Licence No. 1718
Mitchell Engineering Food Equipment Pty Ltd



WaterMark
WM - 022559
AS/NZS 3718



CAT 67913

Hot & Cold Mixer – Chrome Plated Deck Mounted

Features

Up to 70% water saved
Hygienic with zero cross contamination
Touch free and accessible activation
"Plug and play" digital infrared sensor technology
Sensing range automatically adjusts to your environment
Easy installation and supplied with everything required, replaces existing ½" connections
No electrical wiring required, 4 x AA batteries or 240V transformer



Includes

Curve Neck spout with fitted sensor
Battery pack (batteries not supplied)
Optional 240V transformer
2 x Braided hoses
2 x Stop Valves
Red and Blue Stickers
Instruction manual

Specifications

Deck Mounted
Chrome Plated
Standard ½" Connection
5 – 22cm Sensing Range
Water Pressure: 0.07-0.7Mpa

Available Finishes

-  CAT 67913 – Chrome Plated
-  CAT 67913B – Matte Black

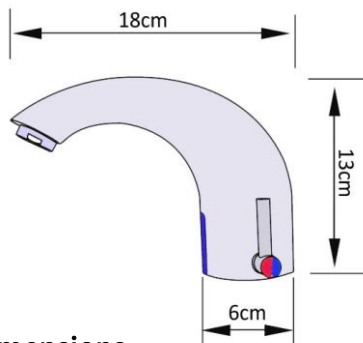

Dimensions

Curve Neck Spout - 13cm high
Tap: 13 x 18 x 6cm, 1.1kg
Boxed: 27 x 25 x 11cm, 2.1kg



MEFE Sensor Taps are WaterMark certified and have been awarded 6 Stars, the highest WELS water efficiency rating. This signifies that our taps are eco-friendly and of the highest quality being AUS and NZ certified. Our range is DDA compliant when installed in accordance with AS 1428.1 2009.

Sensor Tap – Tall Upright



WATER RATING
www.waterrating.gov.au

5.5 litres per minute

In accordance with AS/NZS 6400

Licence No. 1718
Mitchell Engineering Food
Equipment Pty Ltd



CAT 67917

Tall Upright – Stainless Steel Deck Mounted

Features

Up to 70% water saved
Hygienic with zero cross contamination
Touch free and accessible activation
"Plug and play" digital infrared sensor technology
Sensing range automatically adjusts to your environment
Easy installation and supplied with everything required, replaces existing 1/2" connections
No electrical wiring required, 4 x AA batteries or 240V transformer



Includes

Upright spout with fitted sensor
Solenoid box (fitted solenoid valve and battery housing, batteries not supplied)
Optional 240V transformer
Braided hose
Instruction manual

Specifications

Deck Mounted
Stainless Steel
Standard 1/2" Connection
5 – 22 Sensing Range
Water Pressure: 0.07-0.7Mpa

Available Finishes

-  CAT 67917 – Stainless Steel
-  CAT 67917B– Matte Black

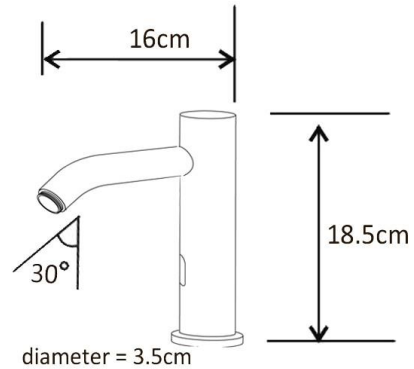

Dimensions

Tall Upright Spout - 18.5cm high
Tap: 18.5 x 16 x 3.5cm, 0.7kg
Boxed: 28 x 22 x 10cm, 1.4kg

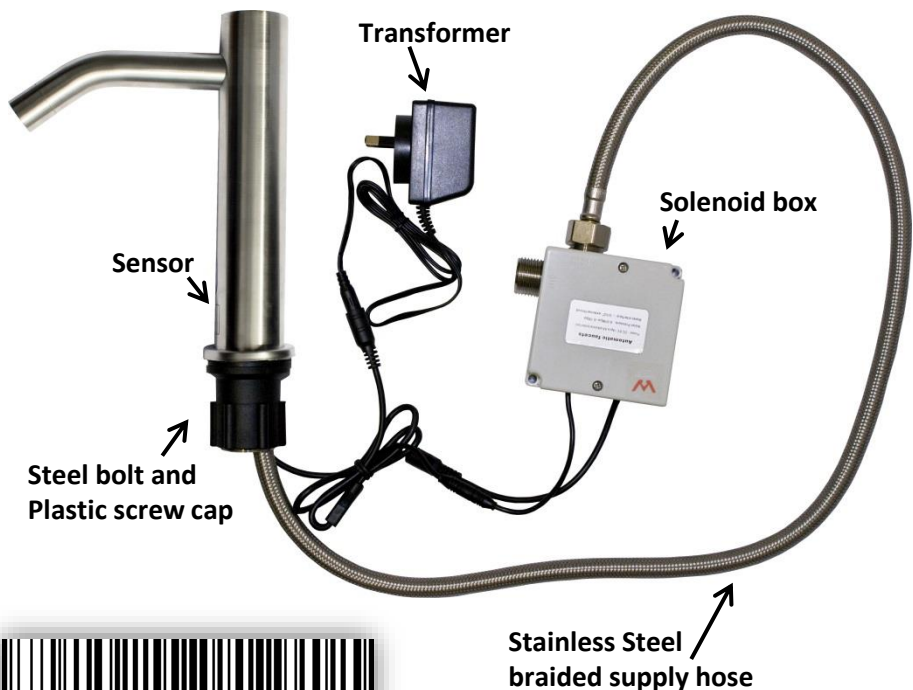

MEFE Sensor Taps are WaterMark certified and have been awarded 6 Stars, the highest WELS water efficiency rating. This signifies that our taps are eco-friendly and of the highest quality being AUS and NZ certified. Our range is DDA compliant when installed in accordance with AS 1428.1 2009.

Sensor Tap - Boomerang



The more stars the more water efficient

WATER RATING
www.waterrating.gov.au

5.0 litres per minute

In accordance with AS/NZS 6400

Licence No. 1718
Mitchell Engineering Food Equipment Pty Ltd

CAT 679178

Boomerang – Stainless Steel Deck Mounted

Features

Up to 70% water saved
Hygienic with zero cross contamination
Touch free and accessible activation
"Plug and play" digital infrared sensor technology
Sensing range automatically adjusts to your environment
Easy installation and supplied with everything required, replaces existing 1/2" connections
No electrical wiring required, 4 x AA batteries or 240V transformer

Includes

Boomerang spout with fitted sensor
Solenoid box (fitted solenoid valve and battery housing, batteries not supplied)
Optional 240V transformer
Braided hose
Instruction manual

Specifications

Deck Mounted
Stainless Steel
Standard 1/2" Connection
10cm Pre-set Sensing Range
Water Pressure: 0.07-0.7Mpa

Available Finishes

- CAT 679178 – Stainless Steel Polished
- CAT 679178S – Satin Finish
- CAT 679178B – Matte Black

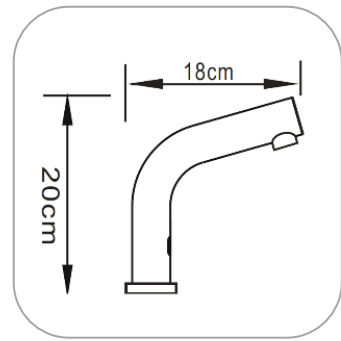

Dimensions

Boomerang Spout - 20cm high
Tap: 20 x 18 x 5cm, 0.5kg
Boxed: 25 x 22 x 6cm, 1.3kg

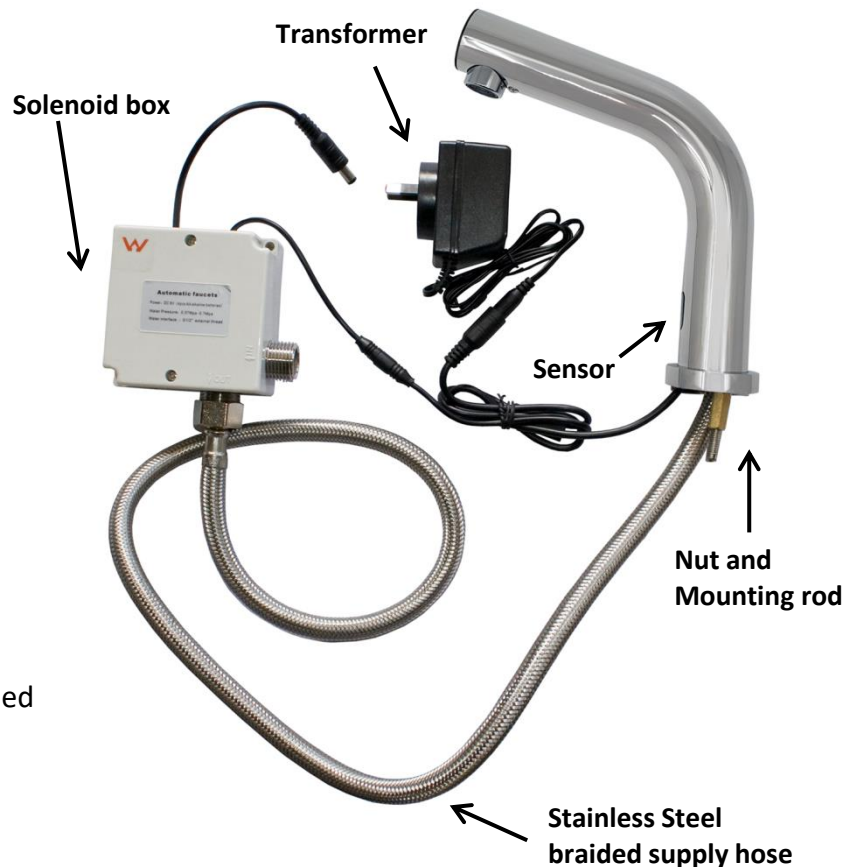

MEFE Sensor Taps are WaterMark certified and have been awarded 6 Stars, the highest WELS water efficiency rating. This signifies that our taps are eco-friendly and of the highest quality being AUS and NZ certified. Our range is DDA compliant when installed in accordance with AS 1428.1 2009.



1800 669 006
info@mefe.com.au www.mefe.com.au
Tel: 07 3283 4536 Fax: 07 3283 4482

